

JURE KONJEVOD SLAVKO KRAJCAR PERICA ILAK
jure.konjevod@fer.hr slavko.krajcar@fer.hr perica-ilak@fer.hr

**University of Zagreb Faculty of Electrical Engineering and
Computing**

THE REAL-TIME COORDINATION OF A WIND-HYDRO POWER GENERATION

SUMMARY

This paper introduces the real-time coordination of the wind and hydro power plants in the case of a part of the Croatian Power System where hydro–wind coordination is represented by Vrataruša wind farm and Senj and Vinodol hydropower plants. The model uses real data which represent generation units that make the power system. Also, the paper describes the general problem which is specific for these type of energy sources. For modeling hydro-wind coordinated generation, the MATLAB/Simulink model is developed. Obtained results, rotor speed, an active and reactive power of wind power plant, voltages, rotor speed, rotor speed deviation, active output power, and stator current of a hydroelectric generator are presented and analyzed.

Keywords: excitation voltage, hydropower plant, output power, rotor speed, wind-hydropower generation system

1. NOMENCLATURE

P	<i>Active power</i>
P_{max}	<i>Total capacity of plant (MW)</i>
P_{eo}	<i>Output power of hydro turbine</i>
Q	<i>Reactive power</i>
Q_i	<i>Installed flow of plant (m³/s)</i>
ω_r	<i>Angular (rotation) speed of wind turbine</i>
ω_m	<i>Angular (rotation) speed of hydro turbine</i>
$d\omega_m$	<i>Angular (rotation) speed deviation of hydro turbine</i>

2. INTRODUCTION

Increasing popular hybrid systems (coordinate generation of two or more energy sources) is due to increased integration of renewable energy sources into existing power systems. Renewable energy technologies enable implementation of hybrid systems [2]. In this paper, we have analyzed a part of the Croatian power system which has a significant share of hydro and wind energy. A characteristic of Croatian power system is that more than a half of all energy sources are produced by hydropower plants [3]. Analyzed part of power system consists of two hydropower plants (HPP Vinodol and HPP Senj) and one wind power plant (WPP Vrataruša). HPP Vinodol is connected to 110 kV transmission grid via three power blocks "generator-transformer" and external switchgear. Total capacity of HPP is 94,5 MW (3 x 31,5 MW) with installed flow $Q_i=16,7$ m³/s. HPP Senj is diversion HPP with total capacity $P_{max}= 216$ MW (3 x 72 MW). Further, HPP Sklope is part of hydro-power system Senj and has $P_{max}= 22,5$ MW with installed flow $Q_i=45$ m³/s. WPP Vrataruša is the first WPP in Croatia which is connected to a transmission line. It has fourteen turbines with a nominal capacity of 3 MW each, having a total capacity of 42 MW. WPP Vrataruša is connected to the transformer station (TS) Crikvenica and HPP Vinodol on the one side, and to the HPP Senj on the other side. According to that, WPP is located between HPP Vinodol and HPP Senj and unavoidably affect their work [4]. The described part of the power system is shown in the Fig.1 (a) where in the Fig. 1 (b) the single pole scheme and the exact values of the analyzed power flows are shown. This example has been analyzed in this paper. Moreover, for simulating and analyzing all relevant parameters, of such a wind-hydro system, MATLAB/Simulink model is used.

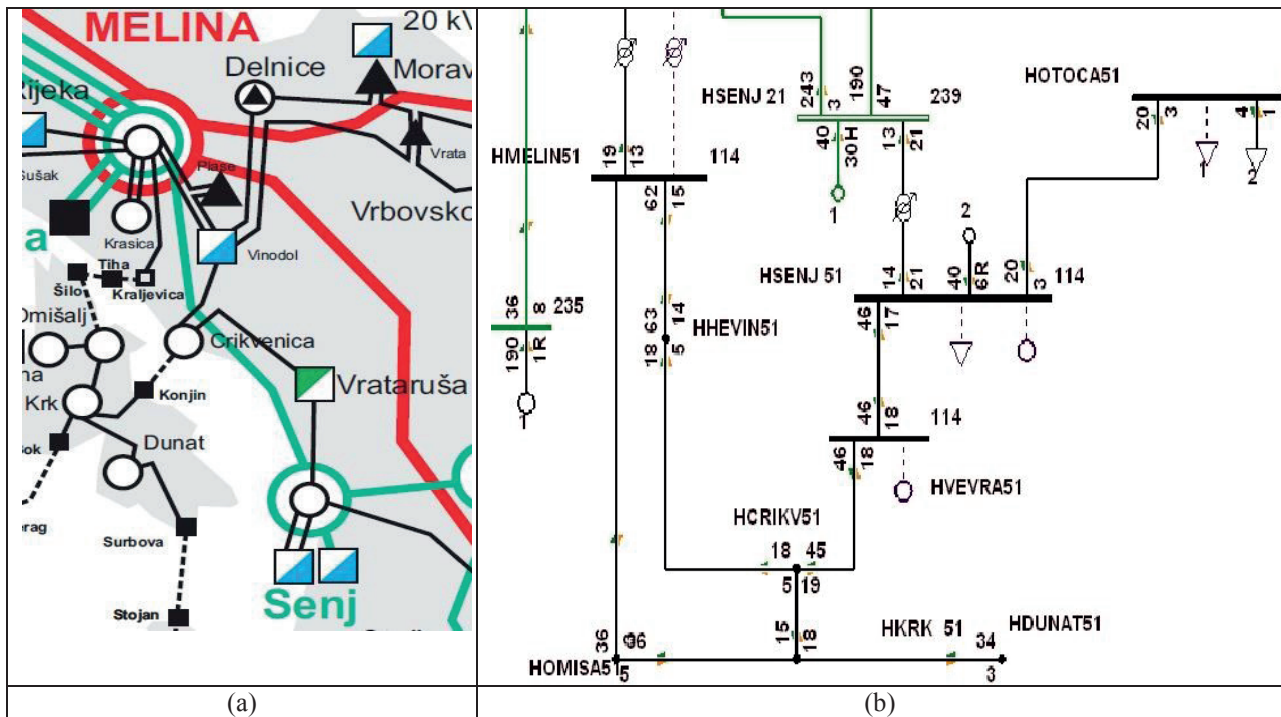

Figure 1. The: a) Analyzed part of the Croatian power system and b) the values of the power flows in the analyzed part of the grid in MW.

3. PROBLEM DESCRIPTION AND FORMULATION

3.1. Connecting wind power to the grid

Connecting wind power plants to the grid remains a significant problem as WPP can meaningfully influence on the system stability and quality of electrical energy (dynamical changes of voltage, i.e., flickers) [5]. Criteria of connecting are defined in the form of “Wind Grid Codes”. Since different types of wind generators are in use, there are also different types of “Wind Grid Codes”. The first one refers to connecting to the transmission system (nominal voltage 110 kV) and the second one refers to connecting to the distribution system (nominal voltage 35 or 20(10) kV).

3.2. Wind power plant grid work

“Problem of surplus wind” is possible to appear during WPP grid work. It is defined as wind energy repulsion for power which exceeds load minus baseload power plants (Figure 1).

Baseload power plants are, for example, nuclear power plants and run-of-the-river plants. Solution to the problem is on the level of international interconnection. When WPP is connected to the grid, the active power dependence of v^3 wind velocity. Since regulation of voltage, active and reactive power depends on operation and excitation of synchronous generator, wind generator represents energy source which causes voltage and power fluctuations in the grid. Also, wind speed is changeable. Wind predictability is a problem which can be reduced using improved wind forecast methods as well as wind turbine blade design and control.

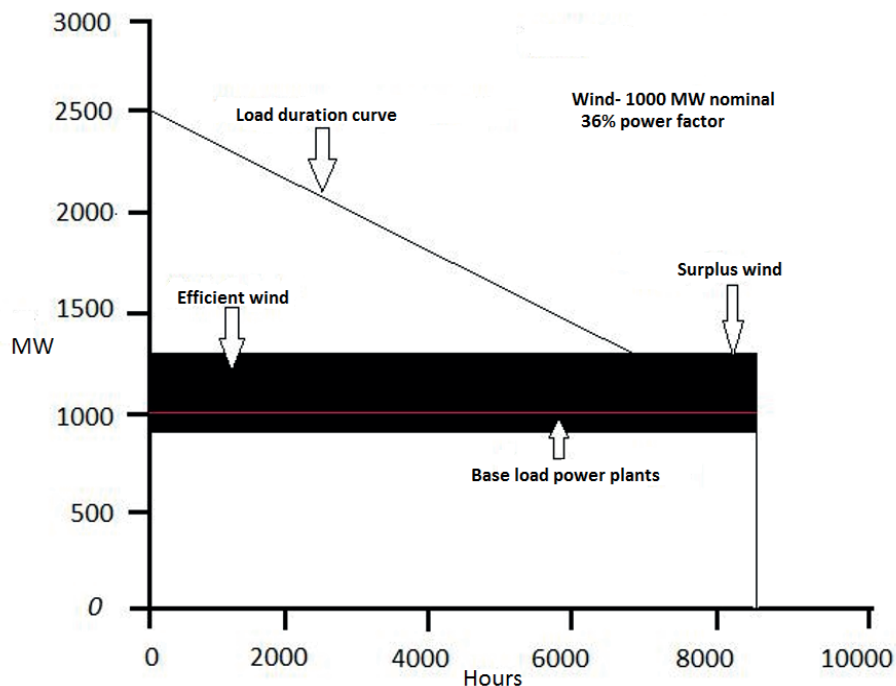

Figure 2. The depiction of load curve with a representation of “problem of surplus wind”

3.2. Hydro energy resources

It is possible to estimate hydro energy resources with knowing or estimation of flow duration curve and net head. There are three types of hydro energy resources: total (theoretical), technical and economically usable. Technical potential is a few times lower than total and about 30% greater than economic. Final usability is determined by ecological, economic and social factors [6].

3.3. Methodology

As mentioned before, for analyzing all relevant parameters the MATLAB/Simulink model is developed. The depiction of MATLAB/Simulink model is shown in the Fig. 3. In addition to that, it is important to say that transformer station 400/220/110 kV Melina, TS 110/20 kV Dunat and switchgear 110 kV Omišalj are considered as well as their mutual connection. Besides, it is modelled connection of HPP Senj to the TS 110/35 kV Otočac and HPP Sklope. All that units are modelled in that way to get a more realistic situation of the grid. Also, basic power flows data of each bus are used. In model are entered values for generation and consumption of active and reactive power of each bus.

Generally, in power flow calculation there are three types of buses: P-Q bus, P-V bus, and slack bus. For P-Q bus known values are active power P and reactive power Q [7]. In this model, P-Q buses are: Crikvenica, Melina, Omišalj, Krk, Dunat, and part of the grid on which HPP Senj is connected. Further, known values for P-V buses are voltage $|V|$ and active power P. Generation units, HPP Vinodol and HPP Senj, are modelled as P-V buses or slack buses what depends on the observed case. 42 MW wind farm is shaped using Doubly-Fed Induction Generator (DFIG). Simulation for the developed model is conducted under certain conditions. Thus, two different cases are analyzed and described in this paper. For hydroelectric generator are analyzed voltages, rotor speed, rotor speed deviation, active output

power and stator current and for wind power plant rotor speed, an active and reactive power.

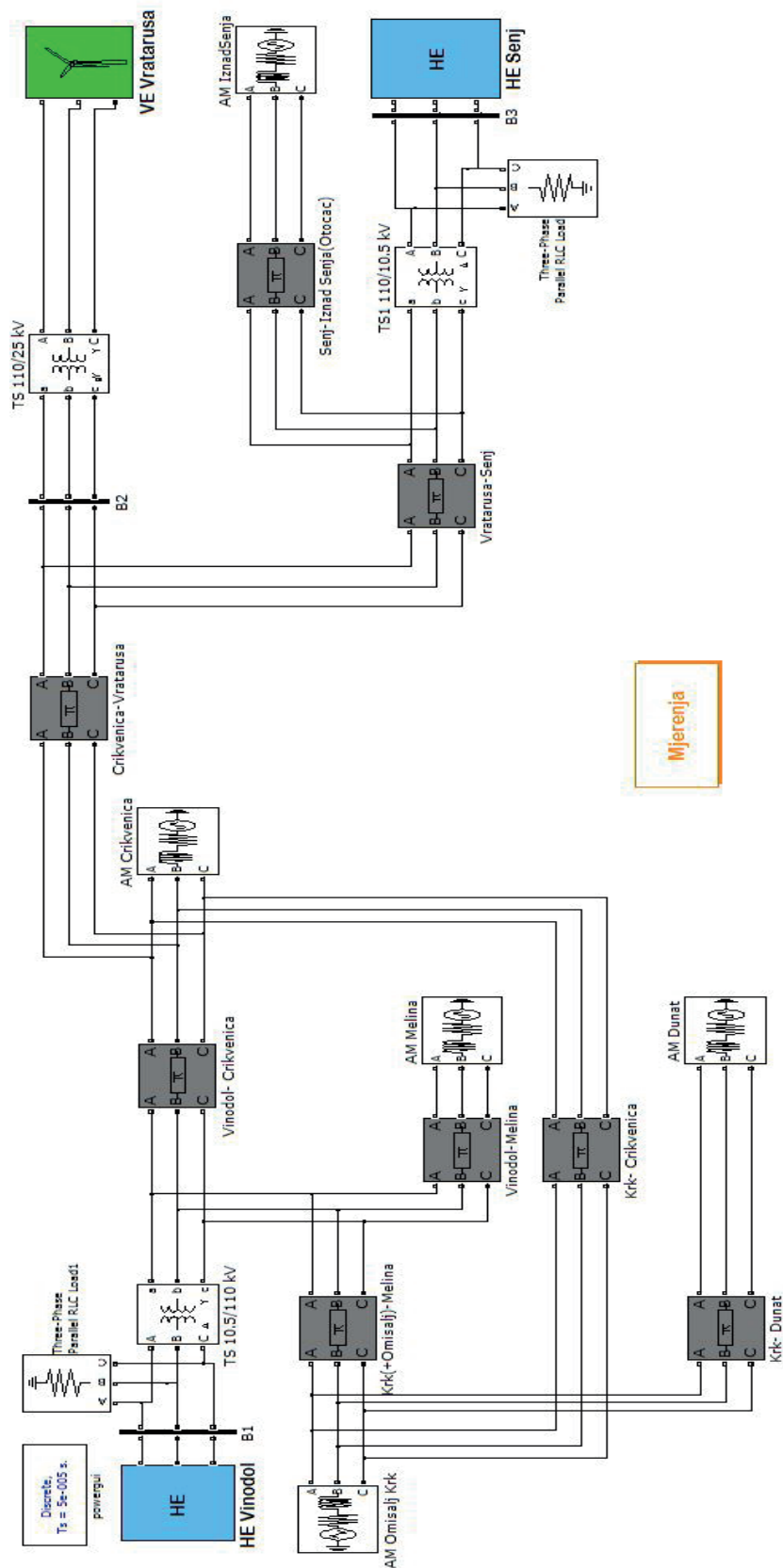

Figure 3. The depiction of the developed MATLAB/Simulink model

4. RESULTS AND DISCUSSION

In the first case, initial conditions are set via *Machine Initialization* block and *Powergui* tool. Further, it is defined that HPP Senj injects 200 MW active power into the grid, HPP Vinodol injects 90 MW, and WPP Vinodol injects 40 MW. In the second case, it is observed 3-phase short circuit which is located on the transmission line Vratarusa-Senj. Fault time is set to appear at 1,6 s of simulated time and has a duration of 0,1 s. Short circuit of three phases, generally, is shown in Figure 4.

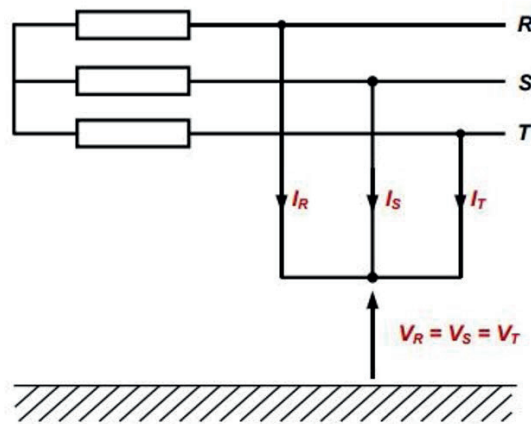

Figure 4. Three phase short circuit

Also, it is defined wind speed function using real data for one day in the year (Figure 5). The function is used in both analysed cases. After simulating the model, obtained results are shown in graphs. The angular speed of wind turbine in the first case (“normal” occasions without short circuit) is provided in Fig. 6 (a). The angular speed had a small collapse at that moment, but when fault elapsed, it came back to stable state (Fig. 6 (b)). Apparently, on both figures, angular speed reaches the steady value at 1,2 s of simulated time. Also, both functions are equal until the fault moment.

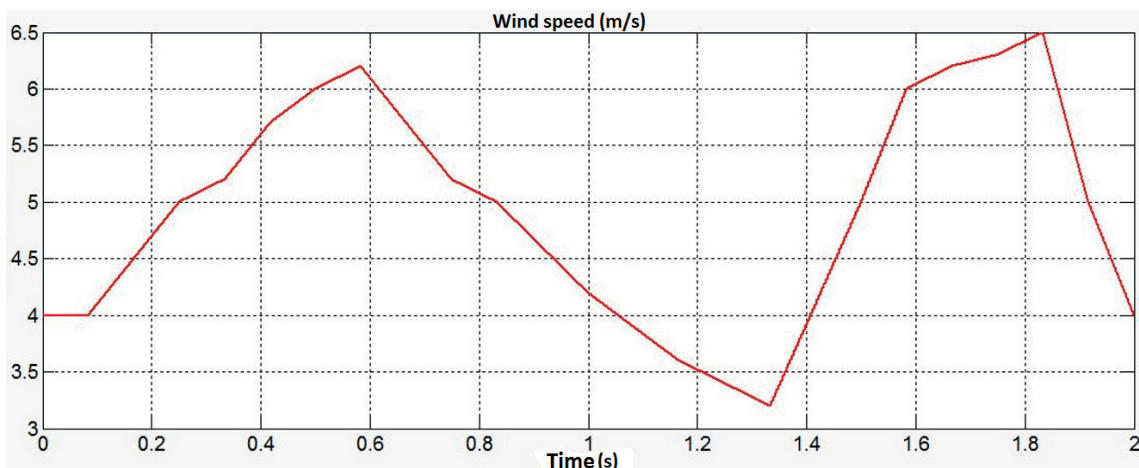

Figure 5. Wind speed function

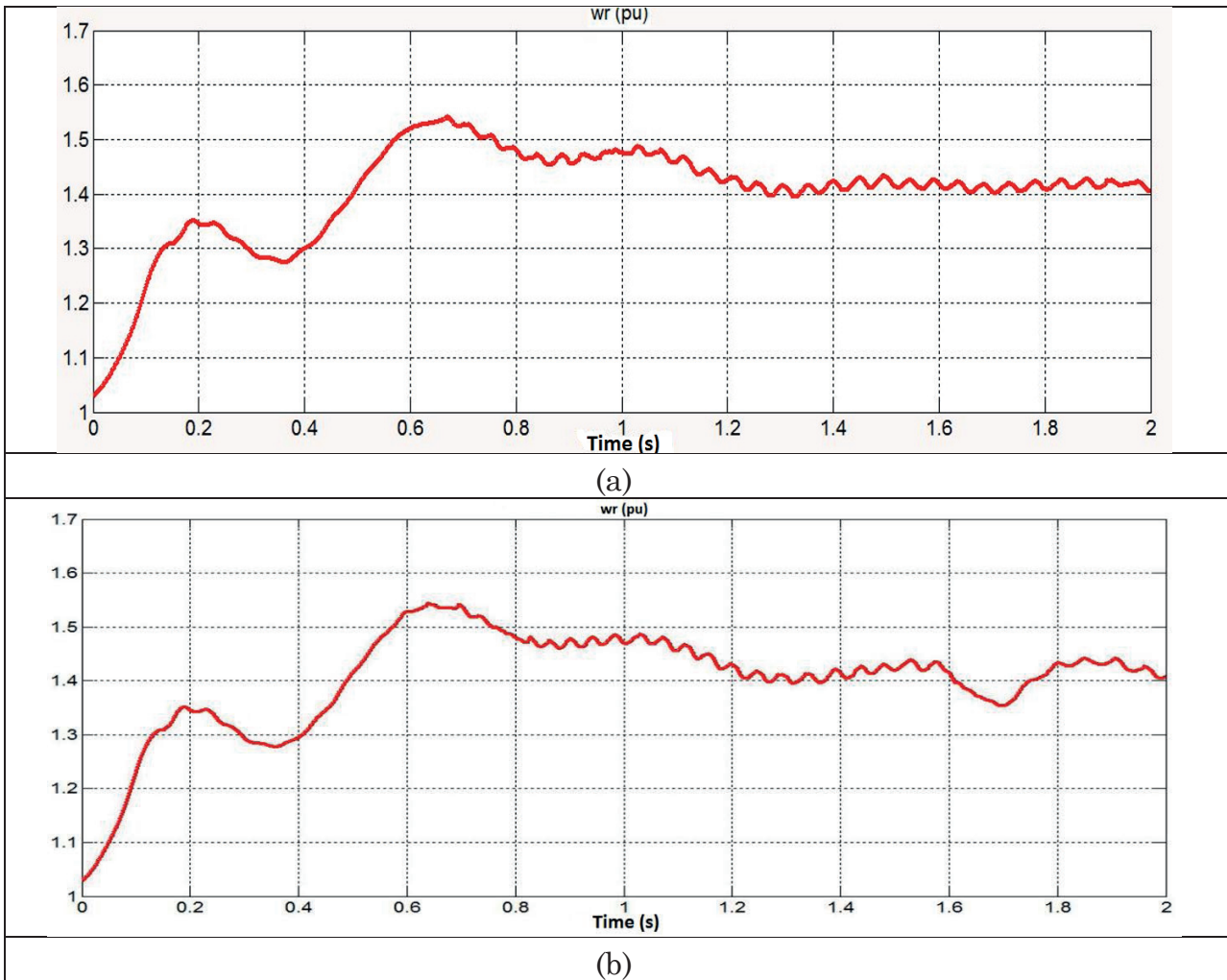

Figure 6. Angular (rotation) speed of wind turbine ω_r in the: a) first case;
b) in the second case.

Dependence of angular speed and active power is visible in graphs in the Fig. 7 and Fig. 8. Larger change of angular speed affects larger change of active and reactive power. Noticeable difference in graphs of active and reactive power between two cases is during the fault time. During this period, wind power plant does not inject active power into the grid. Also, it is visible (Fig. 9 and Fig. 10) that reactive power of WPP is about 0 MVar during the fault.

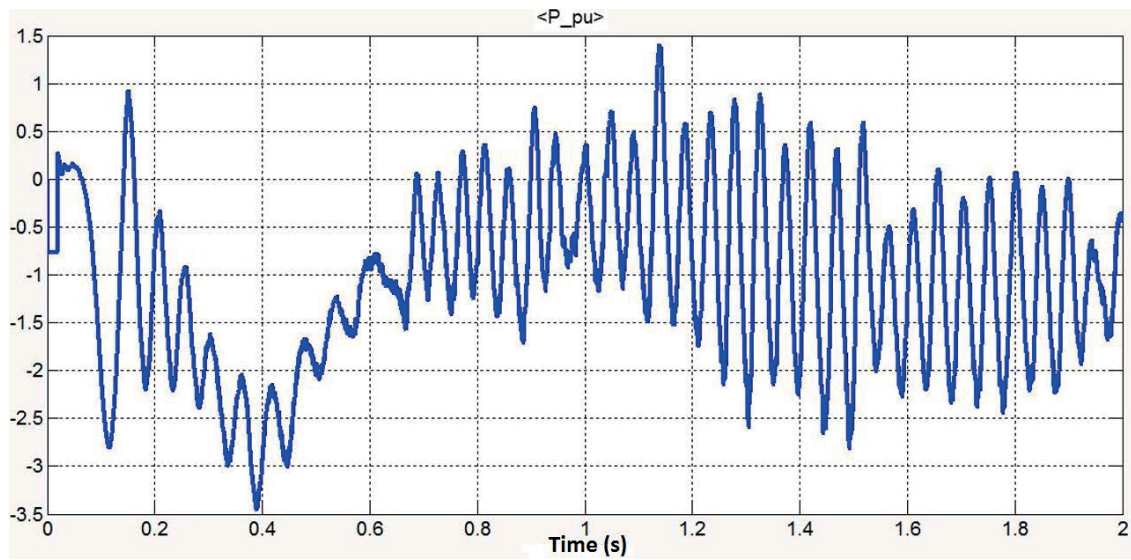

Figure 7. Active power of wind power plant in the first case

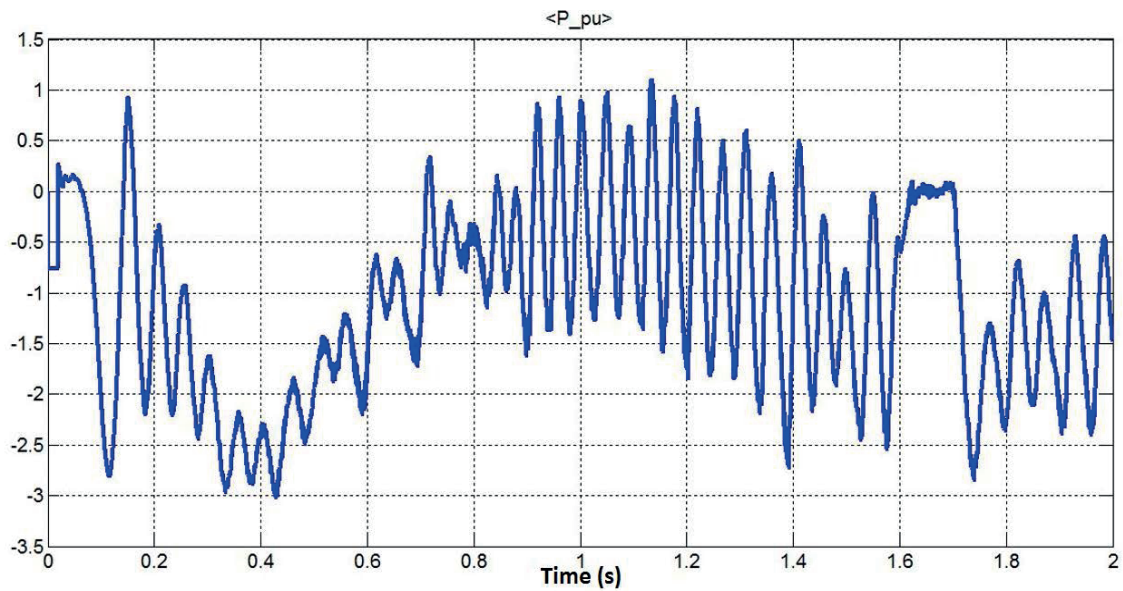

Figure 8. Active power of wind power plant in the second case

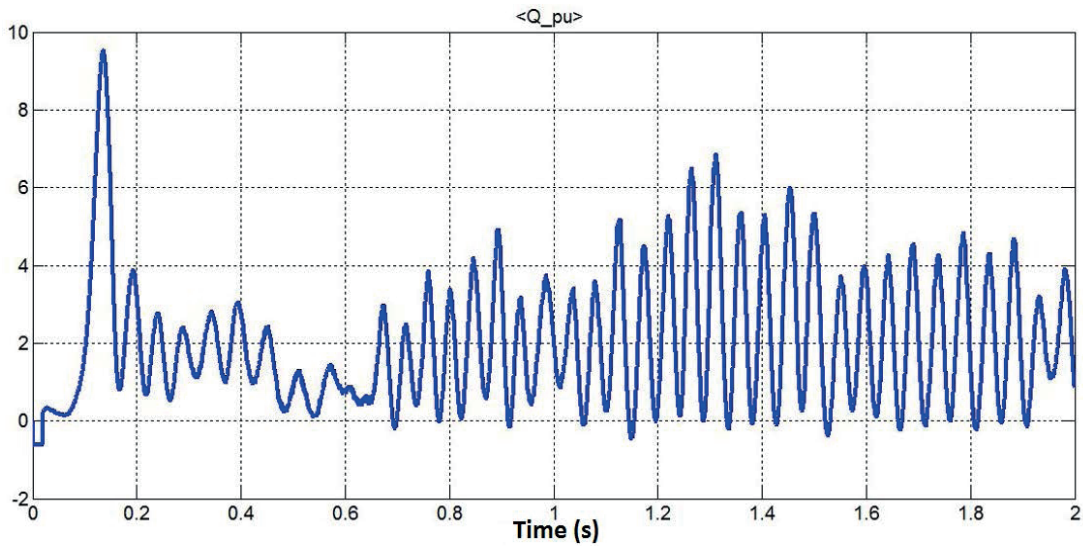

Figure 9. Reactive power of wind power plant in the first case

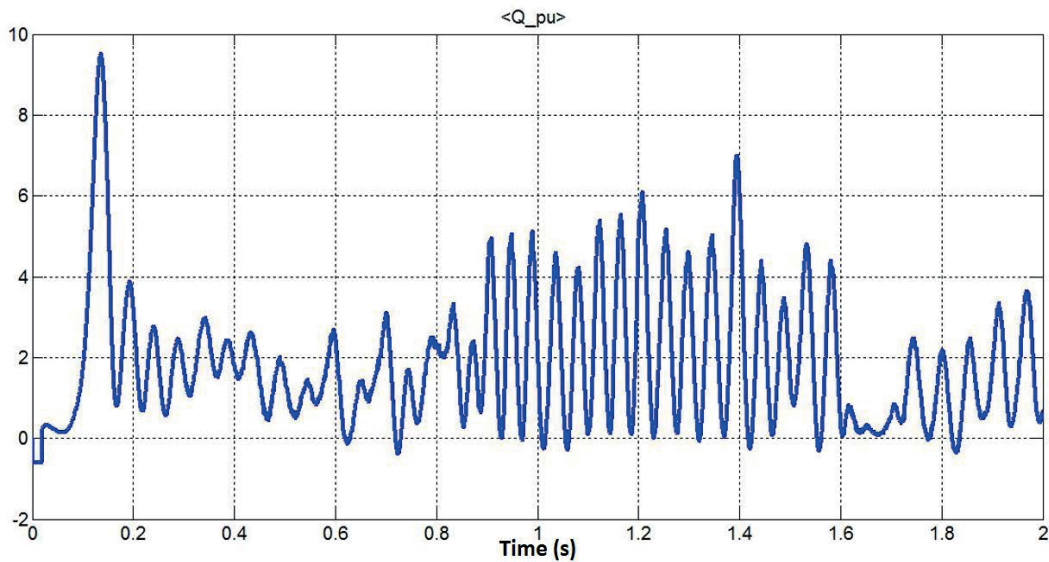

Figure 10. Reactive power of wind power plant in the second case

Excitation system provides generator voltage quality and reactive power. Also, it provides stable work of generator on the grid or in parallel work with other machines. Change of excitation voltage (Fig. 11) and reactive power of asynchronous wind generator (Fig. 10) are mutually connected. It is especially noticeable at 0,1 s when wind generator takes a large amount of reactive power for producing rotating magnetic field (peak of reactive power in Fig.10).

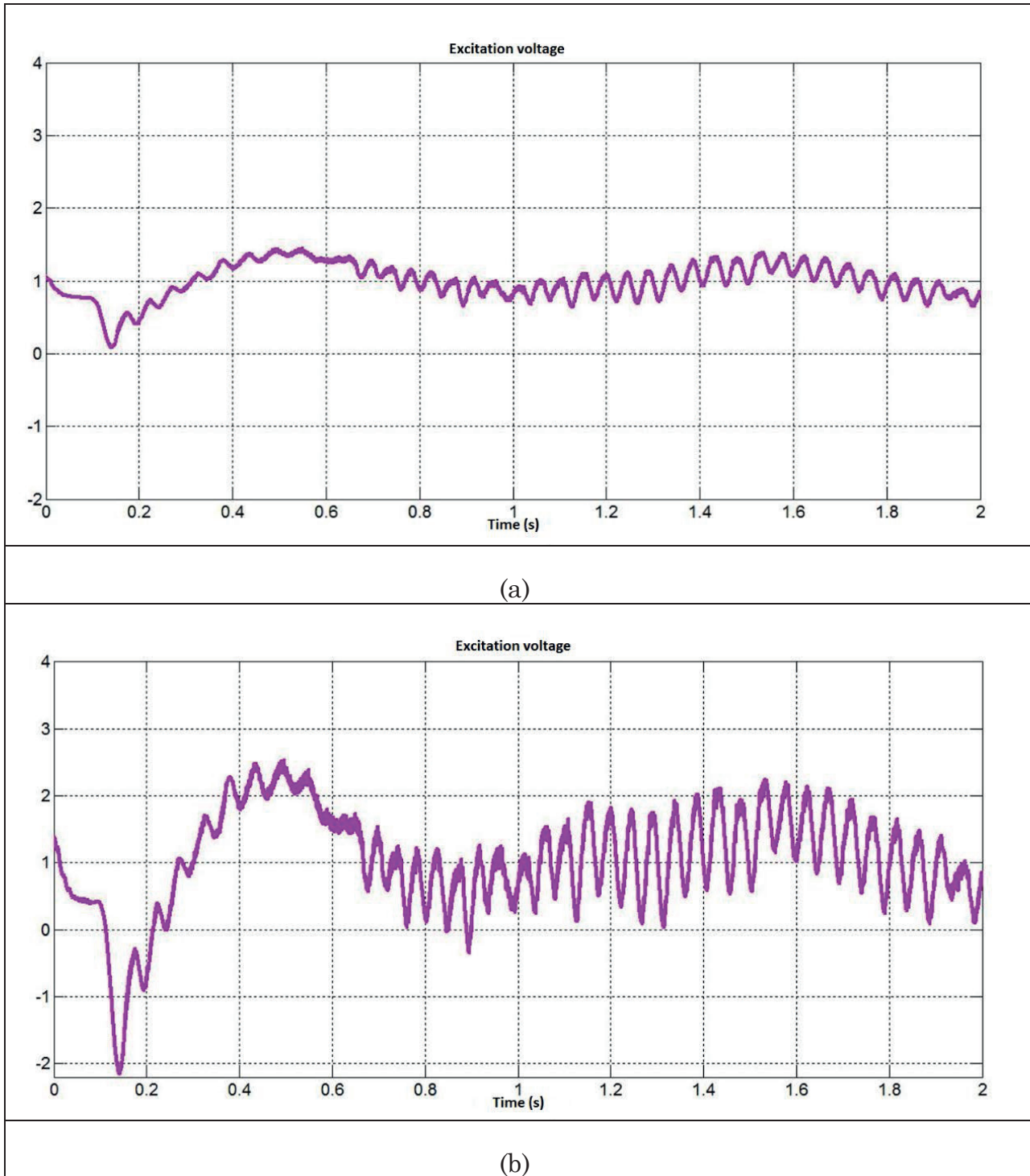

Figure 11. Excitation voltage of hydro power plants of tha: a) Vinodol and; b) Senj for the first case.

Also, on the graphs it is noticeable that excitation voltage of HPP Senj takes more oscillations than HPP Vinodol. It is important to mention that power of HPP Senj is 235 MVA and 105 MVA of HPP Vinodol. Thus, in parallel work, the load is proportional to the power of generators. Also, the connection of this wind-hydro system affects change of excitation voltage at 0,1 s because HPP Senj is directly connected to the WPP via transmission line Senj-Vratarusa. While HPP Vinodol is connected to the WPP with two transmission lines (Vinodol-Crikvenica and

Crikvenica-Vratarusa) and TS Crikvenica is located between that lines. When a fault occurs (Fig. 12), the growth of excitation voltages of synchronous generators is visible on graphs. During the fault time, values of excitation voltages reach the maximum upper limit. As mentioned before, excitation system is trying to provide a final voltage within the limits as it was during normal occasions without a short circuit.

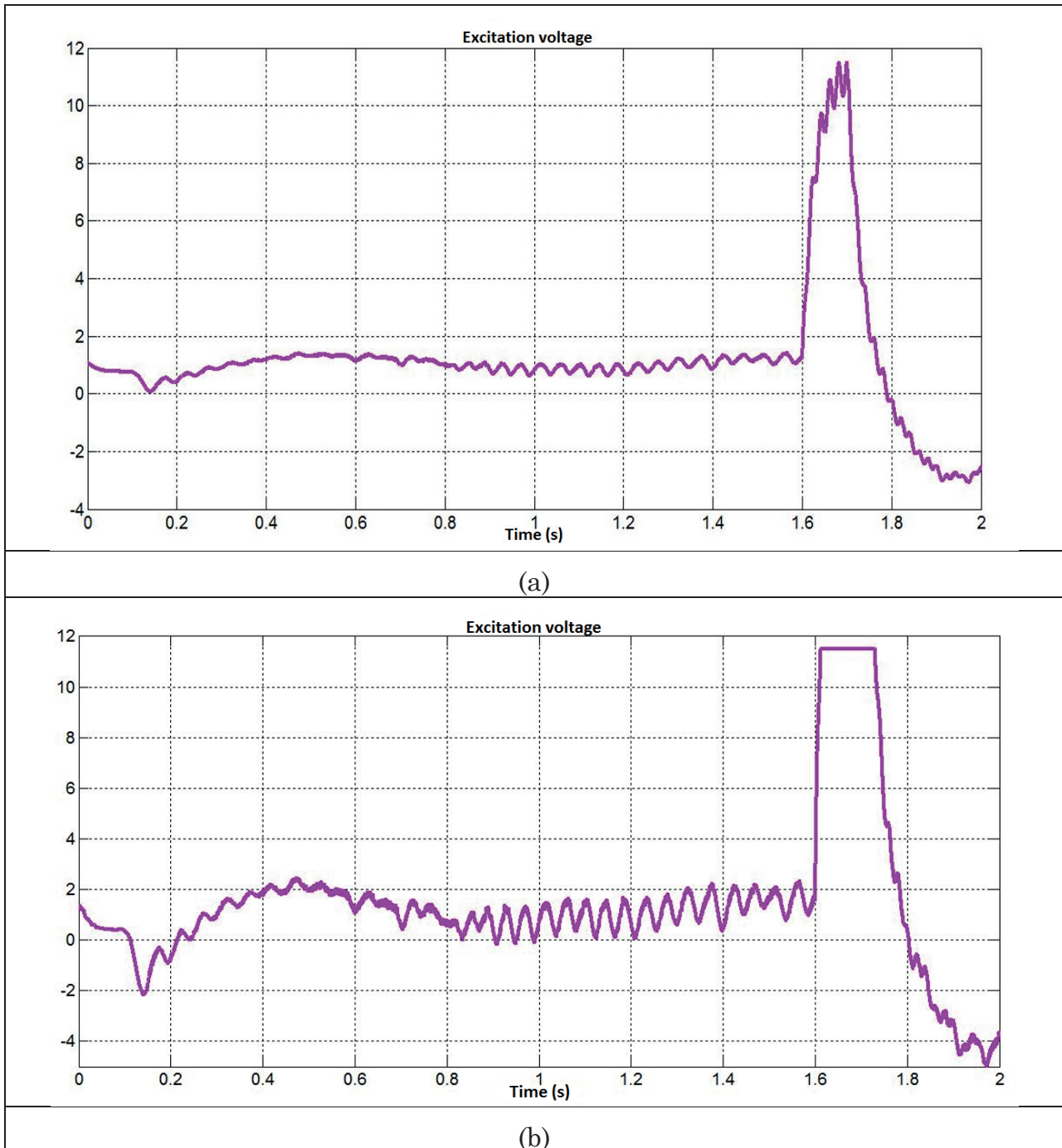

Figure 12. Excitation voltage of hydro power plants: a) Vinodol and; b) Senj for the second case

Angular speed has minimal changes until the fault occurs. When the fault occurs angular speed as well as its deviation has growth slightly and then collapse as noticeable in the graph in the Fig. 12. Angular speed affects output power of HPP which means that machine is trying to increase angular speed to compensate decreasing of output power. When a short circuit elapsed, output power increases slightly in relation to state before the fault had occurred (Fig. 13). That is the reason why angular speed gets a decrease. Parameters shown on graphs (Fig. 13) are related to HPP Senj. But functions for HPP Vinodol, which are not shown on graphs, has the same trend just with smaller oscillations. Causes of significant oscillations for HPP Senj are short circuit location, machine inertness and size of nominal power.

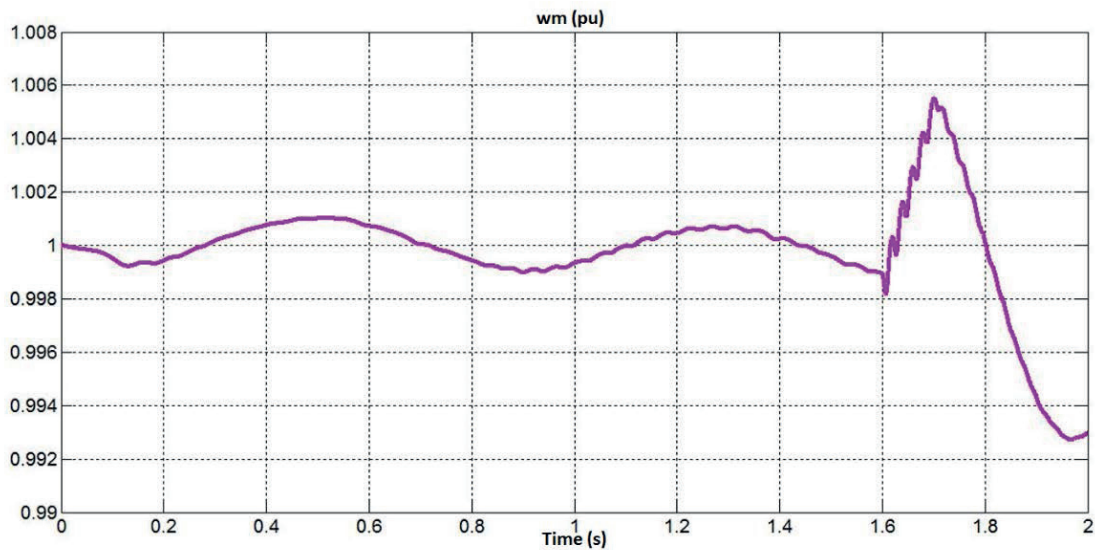

Figure 12. Angular (rotation) speed of hydro turbine for HPP Senj in the second case

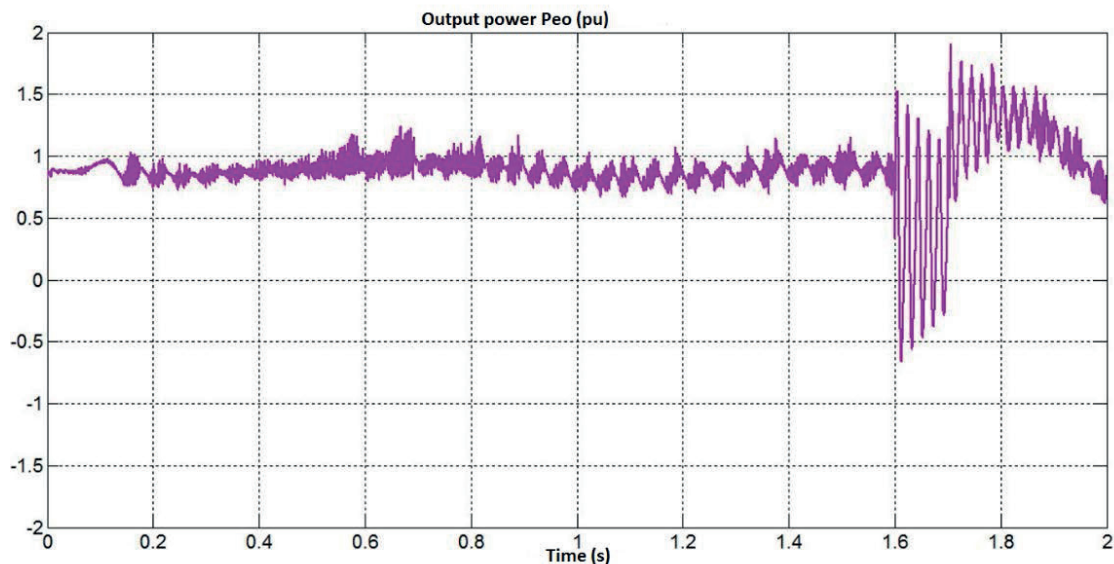

Figure 13. Output power of hydro turbine for HPP Senj in the second case

Three-phase stator current is shown in Fig. 14. Three single-phase alternating currents had sine waveform, equal amplitudes and separated by 120° until the fault occurs. Distortion is visible during the fault time. Three-phase stator current for HPP Vinodol has the same trend, but with smaller distortion. Since the HPP Senj is nearer the fault location, fault affects much more its generator rotation speed. Thus, fault affects rotating magnetic field which is produced by excitation winding. That rotating magnetic field acts via electromagnetic induction to induce a voltage in the armature windings of the stator. Further, the stator's output to the system is a three-phase alternating current (Fig. 14).

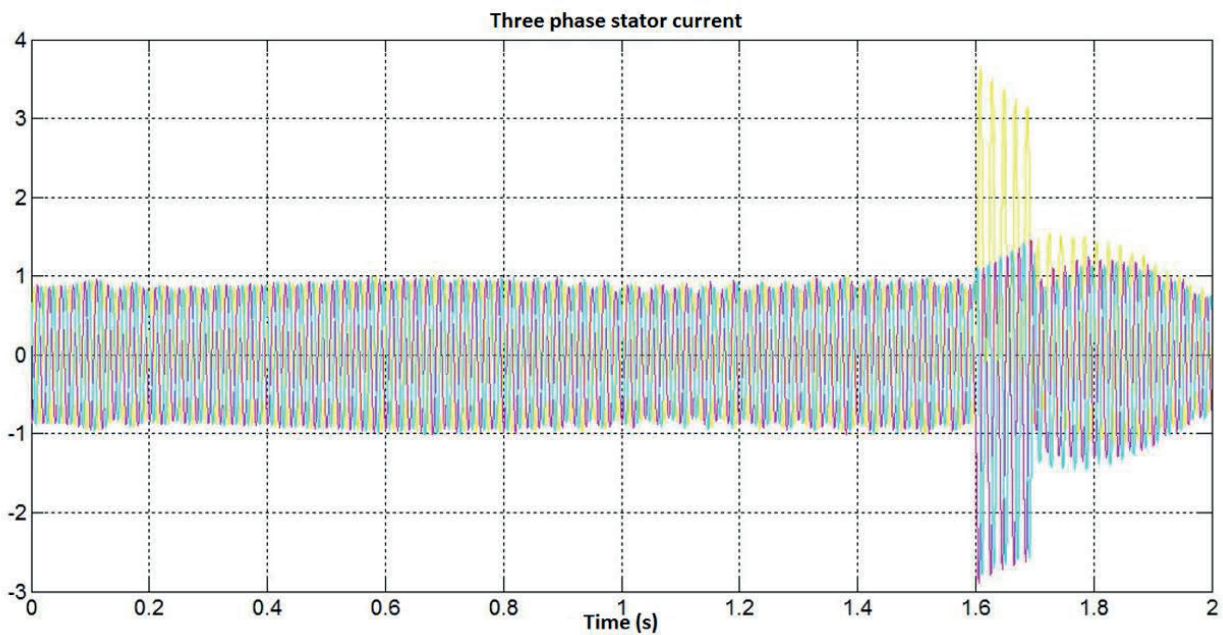

Figure 14. Three phase stator current of hydro generator for HPP Senj in the second case

5. CONCLUSION

After observing and analyzing modelled power system, it can be concluded that active output power of WPP is much more dependent on wind speed than on the load. Also, regulation of voltage, active and reactive power depends on operation and excitation of synchronous HPP generators. WPP is a fluctuating source of energy and causes voltage and power fluctuations as wind speed changes. It is necessary to install much more capacities on a wider area to improve the stability of this energy source. Besides, wind generator affects voltage increasing at the connection point of wind power plant to the grid. According to that, wind energy has a potential for more efficient use within hybrid wind-hydro systems. This can be implemented with storing wind energy when it is available and then supply the power to the grid if there is a demand. Energy storage in observed hybrid systems enables compensating those periods when there is no wind to fulfill market or grid obligations.

6. REFERENCES

- [1] Jure Konjevod, *Koordinirani rad u stvarnom vremenu vjetrene i hidroelektrane* (eng. *The Real-Time Coordination of a Wind-Hydro Power Generation*), Diplomski rad, Fakultet elektrotehnike i računarstva Sveučilište u Zagrebu, 2016. Mentor: S. Krajcar
- [2] K. Kumar, M. A. Ansari, *Design and Development of Hybrid Wind-Hydro Power Generation System*, *IEEEExplore*, 2013.
- [3] Osnovni podaci, Hrvatska Elektroprivreda, HEP-Proizvodnja, <http://proizvodnja.hep.hr/osnovni/hidroelektrane/default.aspx>, 2016.
- [4] Shema EES-a, Hrvatski operator prijenosnog sustava-HOPS, <https://www.hops.hr/wps/portal/hr/web/hees/podaci/shema>, 2016.
- [5] M. Lasic, D. Škrlec, *Influence of variable-speed wind turbine on voltage quality*, Konferencija HO CIRED, Šibenik, Croatia, 2008.
- [6] D. Šljivac, Z. Šimić, *Obnovljivi izvori energije - vrste, potencijal i tehnologija*, DOOR, Zagreb, 2009.
- [7] I. Pavić, M. Delimar, *Predavanje 5: Proračun tokova snaga*, Predmet - Analiza EES-a, predavanja FER 2015.