

## REGIONALLY IMPORTANT SINCRO.GRID SMART GRID PROJECT

**S. JAMSEK\***  
ELES  
SLOVENIA

**S. TOT**  
ELES  
SLOVENIA

**M. LASIC**  
HOPS  
CROATIA

**I. PERISA**  
HEP ODS  
CROATIA

**M. MIKLAVCIC**  
SODO  
SLOVENIA

### SUMMARY

Regional transmission and distribution challenges has evolved and changed a lot in recent years. Four contradictory influences increasingly affected the operations of Slovenian and Croatian electricity systems. Regional electricity systems experienced increasing support of RES integration to meet the EU targets, a lower electricity consumption due to the economic crisis, a growing lack of centralized electricity production for electric system support and the high interconnectivity between the neighboring control zones. TSOs and DSOs observed growing network overvoltage issues as well as a decrease in secondary reserve capacities. Such situation starts to impact national and regional renewable integration targets affecting the security of supply at European level. SINCRO.GRID joint investment project addressed the above-mentioned issues in a sustainable manner. Such cross-border systemic approach will bring synergetic benefits. It will enable an acceptable level of security of operation for at least the next ten years hosting levels of RES in line with the trends foreseen to reach the 2030 targets safely. The project is going to integrate new active elements in the transmission and distribution grids. It leans on the following main pillars: deployment of six compensation devices, deployment of advanced dynamic thermal rating (DTR) systems, deployment of electricity storage systems, integration of distributed renewable generation (DG) and deployment of a virtual cross-border control center (VCBCC). A key aspect of the SINCRO.GRID project lies in the synergy brought by the simultaneous innovative deployment of a portfolio of mature technology-based solutions bring high benefits and positive externalities for the region and European Union.

### KEYWORDS

Regional Impact – Innovation - Project – Investment - Smart Grid - Compensation Devices - Electricity Storage - Virtual - Cross-border - Control Center - Dynamic Thermal Rating - Distributed - Renewable Generation - Overvoltage - Secondary Reserve.

## 1 INTRODUCTION

Regional transmission and distribution challenges has evolved and changed a lot in recent years. SINCRO.GRID is a project proposal of four promoters from two neighboring countries as an answer to these challenges and network issues using a systemic approach. Storyline [1] of the project describes the origin and its impact addressing different stakeholders. The outline of project storyline is presented in this paper. Comprehensive information is given about its main components as well as description of project benefits and costs. The project achieved PCI status in 2015 and obtained European co-funding on the second call for proposals in 2016 (CEF-Energy-2016-2). An important project success factor is achievement of positive externalities along three lines: macro-regional security of supply, solidarity with other countries and technological innovation with replication potential.

## 2 ORIGIN AND IMPACT OF THE PROJECT

Primary tasks of Transmission System Operators (TSO) are enabling security of operation, facilitation of regional markets and integration of renewable energy sources (RES). Thus, development of grid infrastructure, supporting technologies and mechanisms are key elements for proper and timely integration of additional RES. All abovementioned results in network development plans, market and grid connection activities. In addition, TSOs also address network-ageing issues and weather related risks with technical solutions that keep the electric system secure at acceptable costs.

In recent years, the Slovenian and Croatian electricity systems have been increasingly challenged by four contradictory influences affecting the operations of both electricity systems:

1. Support of RES integration to meet the EU targets,
2. A lower electricity consumption due to the economic crisis,
3. A growing lack of centralized electricity production for electric system support,
4. The high interconnectivity between the neighboring control zones.

Consequently, the Slovenian and Croatian TSOs and DSOs observe growing network overvoltage issues as well as a decrease in secondary reserve capacities in the recent years. Security of supply is therefore at stake and has already had an impact on national and regional RES integration targets.

The Slovenian and Croatian TSOs and DSOs started separately addressing these issues in 2014. Classical engineering approaches to address them were taken into account in the two existing TYNDPs. The implementation of technical measures within each control zone was studied first, with a common conclusion that:

- Uncoordinated actions taken in one of the two control zones would significantly impact the other since these two control zones are highly interconnected;
- A progressive deployment of technological solutions would be less efficient since the same issues would resurface soon, leading to repeated investments in order to keep the security of operation above the bottom line;
- In the long run, uncoordinated approach would never lead to a satisfactory level of security of operation while allowing for hosting higher levels of RES integration and maintaining a sufficient level of ancillary services in both electricity systems.

Therefore, joint actions would create synergies and solve the problem in a sustainable way.

The TSOs and DSOs therefore agreed to work together to address all the pending issues and designed a joint cross-border systemic approach to bring enduring solutions to all of the four above issues at once. They end up with the SINCRO.GRID investment project: it is an innovative system integration of several mature technology components where synergies among all the proposed solutions are searched to maximize the investment impact onto both electric systems and create further regional benefits. SINCRO.GRID project will deliver an increased and acceptable level of security of operation for at least the next ten years, with no additional requirements for repeated investments to maintain the acceptable security level and at the same time the possibility to host increasing amount of RES integration to reach the 2030 targets in an integrated and competitive market.

The SINCRO.GRID project integrates new active elements in the transmission and distribution grids, which are managed via a virtual cross-border control center involving advanced data management, common system optimization and generation/consumption forecasting, thanks to an increased cross-border cooperation between TSOs and DSOs.

A key aspect of the SINCRO.GRID project lies in the synergy brought by the simultaneous deployment of a portfolio of mature technology-based solutions: jointly, they bring high benefits and positive externalities. Those synergies are illustrated below by Figure 1 while the VCBC allows for orchestrating the whole portfolio of solutions.

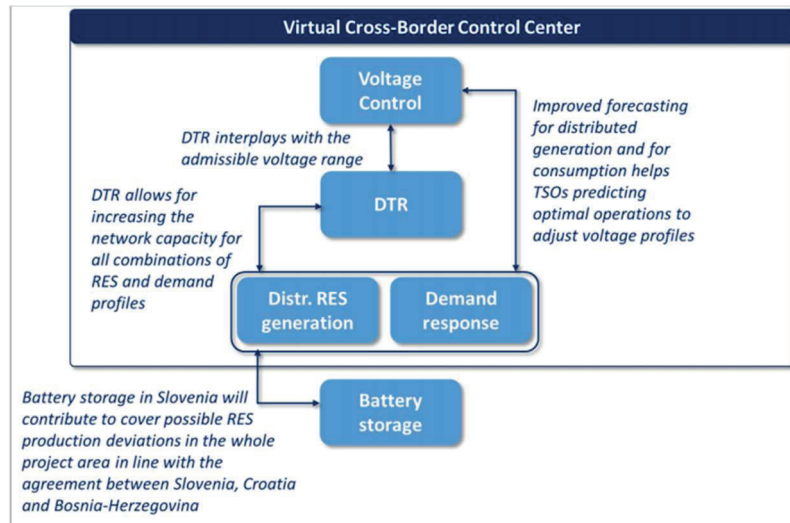

Figure 1: SINCRO.GRID synergies

Bringing these components jointly into play is technically challenging: experience gained can be knowledge-transferred to others DSOs and TSOs.

National regulatory authorities (NRA) of Slovenia and Croatia have examined the SINCRO.GRID project: a strong support was given by the two NRAs, however, cannot commit to full project cost recovery by network tariffs. Firstly, the economic conditions in Slovenia and Croatia do not allow for making network users support the full project costs. Economic simulations show that the transmission tariff in Slovenia would increase up to 9%, which would be unbearable for users connected to the transmission network. Second, full inclusion of the project by NRAs would render it necessary to defer or cancel other projects, which have been included in the national TYNDPs, causing other potential system security issues coming from network ageing or weather-related issues not any more addressed by the reshuffled portfolio of foreseen investments. For example, project Koper-Izola-Lucija internal line and various transformer upgrades in Slovenia, 110 kV Adriatic undersea cable projects connecting islands of Krk and Brac with mainland and revitalization of various aged overhead lines (220 kV OHL Zakucac-Bilice, 110 kV OHL Matulji-Lovran-Plomin, etc.) in Croatia would need to be deferred. As this would cause consumer security of supply issues investment deferment is not viable. Thus, the current technical, economic and regulatory framework in Slovenia and Croatia allows for covering at most 50% of the TSOs' eligible investment costs.

The project cost-benefit analysis (CBA) [2] shows that on top of the benefits brought to the project promoters (already taken into account in the financial net present value FNPV), other positive externalities are brought by the project along three lines:

1. Macro-regional security of supply: the connection of new RES-based electricity generation as well as provision of ancillary services is provided in a securely manner and has an impact on a wider regional level. This increased regional security of supply improves the security of supply at European level since the area is hosting major transit flows from East (Bulgaria / Romania / Ukraine) to West (Italy / Switzerland / France / Germany). Overall, this project improves the EU Internal Electricity Market by increasing potential for transits arising from regional electricity sources (RES and other) without new interconnectors. This would improve the liquidity and resilience of the energy system and would allow full use of the region's energy efficiency and renewable energy potential.

2. Solidarity with other countries: mostly all neighboring countries of Slovenia and Croatia (e.g. Hungary, Austria, Italy, etc.) will directly benefit from the improved security of operation in Slovenia and Croatia. In particular, Bosnia and Herzegovina will draw directly upon the available sources to activate power reserves in the Slovenia-Croatia-Bosnia control block more efficiently. This will be more and more relevant when unpredictable production from renewable energy sources makes it more difficult to ensure a safe and reliable operation of interconnected electric power systems.
3. Technological innovation with replication potential: at a time where one of the next Horizon2020 call for proposal invites research and innovation activities about “Tools and technologies for coordination and integration of the European energy system”, SINCRO.GRID delivers five synergetic technology building blocks which meet some of the Horizon2020 research and innovation specifications. Here lies the potential for replication, where the first TSOs for the deployed solutions are the other regional TSOs, which will learn from this systemic approach in view of preparing the possible implementation of similar technology building blocks.

The SINCRO.GRID project promoters applied for CEF funding, proposing an innovative systemic approach integrating several innovative, yet mature, technologies to solve short term security of supply issues impacting Slovenia and Croatia. This will in turn progressively allow the connection of new RES-based electricity generation in these Member States and the SEE region. Co-funding was awarded on the second call for proposals in 2016 (CEF-Energy-2016-2).

### 3 MAIN COMPONENTS OF THE PROJECT

The concept of different technological solutions put together into the smart grid project solution SINCRO.GRID is shown on Figure 2.

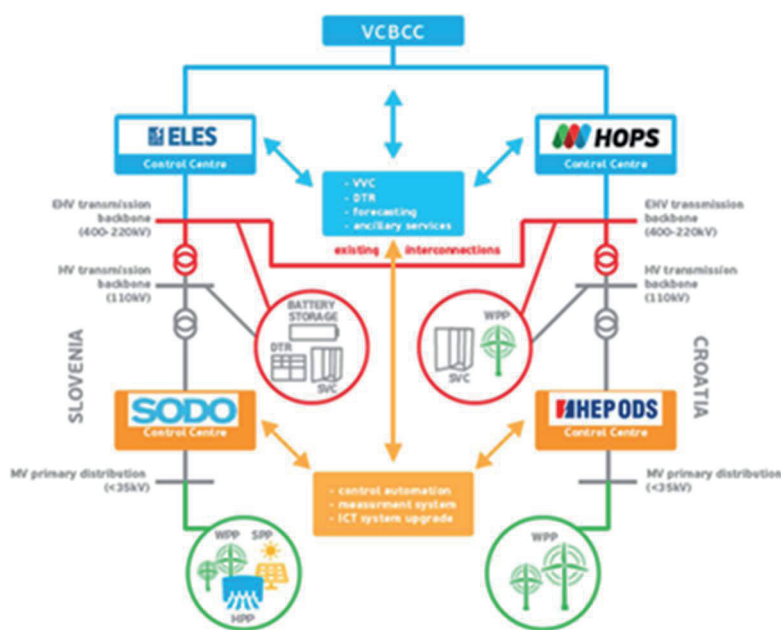

Figure 2: The SINCRO.GRID Project structure

The main components of the project are:

- The deployment of compensation devices to address overvoltage and voltage instability issues within the transmission grid. Multiple reactive power compensation devices will be implemented throughout Slovenia and Croatia (3 locations in Slovenia and 3 locations in Croatia) to tackle the rising problem of voltage control. Common approach and joint cross-border coordinated operation of these devices will bring positive effects to electric power systems of Slovenia and Croatia and neighboring systems as well.

- The deployment of advanced dynamic thermal rating (DTR) systems in both the Slovenian and Croatian transmission grid, tailored to operation under alpine weather conditions and rough terrain. Methods and software are being developed to deal with the highest possible power flows of the lines, considering all weather situations. DTR system uses different heterogeneous subsystems from different vendors, and the results of the calculations are aggregated and are shown in the network control center by means of a visualization platform.
- The deployment of electricity storage systems. Batteries with a capacity of 10 MW will be installed in Slovenia to support the solidarity agreement among Slovenia, Croatia and Bosnia-Herzegovina regarding the secondary active power control.
- The integration of distributed renewable generation (DG). In Slovenia, 2 MW of DG sources with the ability to accumulate primary energy (small hydro, biogas) are integrated into the virtual power plant for the same purpose as for the above batteries. An advanced, short-term forecasting tool for demand and DG generation is established at DSO and TSO levels.
- The deployment of a virtual cross-border control center (VCBCC) for renewable energy sources (RES). It will consist of dedicated IT infrastructure and software to be used by system operators for the efficient and coordinated management of RES. The equipment and operation of the virtual center will be distributed between the existing control systems of system operators (TSOs and DSOs). Advanced algorithms for VVC optimization, secondary reserve, advanced real time operation of the grid using dynamic thermal rating, and a communication platform of the demand side will be established.
- Common Platform for the purpose of efficient data exchange between TSO and DSO to increase possible introduction of demand response into tertiary reserve.
- Establishing efficient ICT infrastructure that will enable data exchange between control centers and on-field equipment.

#### 4 THE PROJECT IMPACT

Quantifiable benefits expected from the SINCRO.GRID project are the following [2]:

- Reduction of GHG emissions,
- Avoided cost of purchasing capacity for secondary reserve,
- Avoided generation capacity investment for spinning reserve,
- Deferred transmission investment,
- Financial benefits due to increased cross border capacity,
- Societal benefits due to increased cross border capacity,
- Reduced cost of equipment breakdowns,
- Reduced electricity technical losses,
- Value of service,
- Decreased amortization value due to longer lifespan of equipment, and
- Decreased cost of purchasing reactive power from generation units.

The quantification and monetization of these benefits leads to a total of 345 M€ of quantifiable benefits, spread amongst Slovenia, Croatia and some neighboring countries. A sensitivity analysis on some key parameters shows high robustness of the project to changes in some specific variables: within our estimations, the total amount of benefits would lie between 202 M€ and 545 M€.

The SINCRO.GRID investment value amounts to 88.6 million Euros in detail elaborated in project Business Plan [3]. Since the project is on European Project of Common Interest (PCI) list, project promoters were eligible to apply for European funding from CEF instrument. The application for Action was submitted in November 2016 and after successful assessment 40.5 million Euro from CEF fund were granted to it. The Action received the highest score among 22 gas, electricity and smart grid projects, which applied for grant on second CEF call in 2016.

## 5 CONCLUSION

Large-scale Smart Grid projects are a challenge for European utilities. It is not easy to meet the PCI requirements and even harder task is a preparation of successful CEF application. European Commission recognized the SINCRO.GRID project as model application and invited project team to promote PCI application preparation for potential Smart Grid project promoters for the third PCI list in 2017. The next challenge is successful project implementation in the next five years. Soundness of the project structure and excellent project team are a good starting point.

## REFERENCES

- [1] ELES, HOPS, SODO, HEP-ODS: SINCRO.GRID Project Storyline, 2016.
- [2] EIMV: Cost Benefit Analysis of SINCRO.GRID Project, 2016.
- [3] ELES, HOPS, SODO, HEP-ODS: SINCRO.GRID A Project of Common Interest Business Plan, 2016.