

## Lightning caused overvoltages on power transformers recorded by on-line transient overvoltage monitoring system

<sup>a</sup>Samir Keitoue, <sup>a</sup>Ivan Murat, <sup>\*b</sup>Božidar Filipović-Grčić, <sup>c</sup>Alan Župan,  
<sup>b</sup>Ivana Damjanović, <sup>b</sup>Ivica Pavić

<sup>a</sup>Končar - Electrical Engineering Institute Inc., Zagreb, Croatia

<sup>b</sup>University of Zagreb, Faculty of Electrical Engineering and Computing, Croatia

<sup>c</sup>Croatian Transmission System Operator Ltd., Kupska 4, 10000 Zagreb, Croatia

### SUMMARY

Transient overvoltages generated by lightning strikes or switching operations represent a significant risk to bushings and windings of power transformers. They cause stress on the insulation system and can, over time, cause dielectric failure and damage to power transformers. Many transformer failures are reported as dielectric failures and they are not necessarily linked to any particular event when they occur but may be the result of prior damage from transient overvoltage events. Lightning and switching overvoltage waveforms appearing at transformer terminals in real operating conditions may significantly differ from standard impulse voltage waveforms used during laboratory testing. The number and amplitudes of overvoltages which stress the insulation depend on various parameters such as the lightning strike density in the considered area, since it determines how often the transformer is stressed by lightning overvoltages. Since the overvoltage amplitudes at transformer terminals are usually unknown, an on-line overvoltage transient recorder can be used with the ability to sample, analyse and store transients in real-time.

In this paper, an on-line transient overvoltage monitoring system (TOMS) for power transformers is presented that is capable to continuously record in real-time various kinds of transient overvoltages such as lightning or switching overvoltages. Special attention is paid to lightning caused transient overvoltages recorded at the terminals of 150 MVA power transformer. Recorded waveforms originating from lightning strikes to overhead lines are correlated with data from the lightning location system (LLS) and supervisory control and data acquisition (SCADA) system. Collected data about overvoltage stresses can be used as the basis for the assessment of the transformer insulation condition, estimation of health index and for analysis of various kinds of events such as faults or equipment failures.

### KEYWORDS

On-line transient overvoltage monitoring system, power transformers, lightning overvoltages, lightning location system.

# 1. INTRODUCTION

Power transformers are one of the key and most valuable components in a power system. Equipping them with an on-line monitoring system is essential for information gathering, condition assessment, better management and decision making. The worldwide transformer reliability survey conducted by CIGRE WG A2.37 and published in [1], collected and analysed 964 major failures which occurred in the period 1996 to 2010, within a total population of 167,459 transformer-years, contributed by 58 utilities from 21 countries. The results point out the main causes of transformer failures, including the reasons with most severe results such as fire or explosion. Fig. 1 shows the failure location analysis according to transformer application in units with voltages 100 kV and above, respectively. The number of failures classified as ‘unknown’ location was 17%, and these ‘unknown’ cases were not considered in the analysis. The failure mode analysis [2] according to application is shown in Fig.1. Windings, tap changer and bushing related failures were the major contributors followed by lead exit insulation related failures irrespective of application or manufacturing period. The failure mode analysis [2] according to application is shown in Fig. 2. Dielectric mode failures were the most prominent, followed by mechanical and electrical type failures, for substation transformers, whereas generator step-up transformers had higher contributions of thermal and dielectric mode failures.

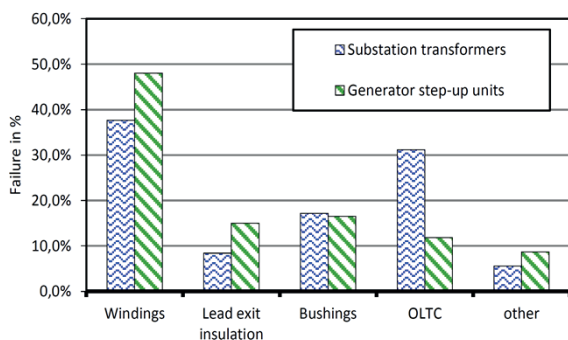

Figure 1. Failure location of substation transformers (536 failures) and generator step-up units (127 failures)

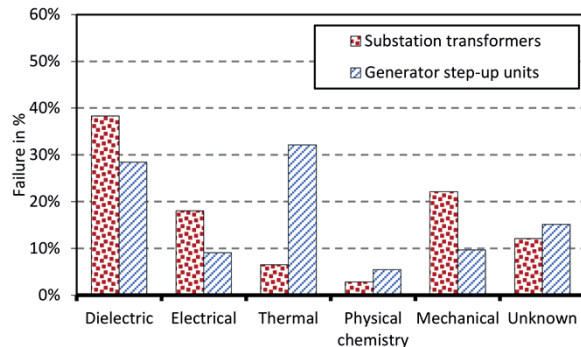

Figure 2. Failure mode analysis of substation transformers (799 failures) and generator step-up units (165 failures)

As can be seen from the survey results, dielectric mode failures were the most prominent, followed by mechanical and electrical type failures, for substation transformers, whereas generator step-up transformers had higher contributions of thermal and dielectric mode failures. Analysis showed that HV bushings significantly contribute to large failures, which means that operators should place large focus on bushing monitoring. Thus, the need for bushing diagnostic and monitoring system has risen.

At present, the performances of oil paper insulation systems of power transformers under switching and lightning overvoltages can be evaluated by testing in HV laboratory with standard lightning and switching impulse voltage waveforms, in accordance with the IEC standard [3]. In actual conditions, however, the waveforms of transient overvoltages that appear on the terminals of power transformer can be extremely complex due to the numerous factors such as the location of surge arresters, the topology of the network, etc. [4-6]. Front and tail time of such overvoltages may be shorter or longer than the standard one defined by IEC standard, and the wave shapes may be very different from the unidirectional double exponentials used in laboratory conditions and may even be bidirectional [7]. Results presented in [8] indicate that transformer winding’s response to certain oscillatory voltages can be worse than that under any form of aperiodic voltages, whether lightning impulse, chopped lightning impulse or steep front - long tailed switching surge. It was shown that terminal excitation at

frequencies coinciding with any one of the winding's natural frequencies may lead to large voltage amplification inside a transformer and can cause severe stresses on insulation. For the above described reason, there is a need to study the characteristics of the transient overvoltages in the field. Transient overvoltages were suspected to be the reason for a number of insulation breakdowns in the last decades, so their monitoring with true waveform recording is of high importance. Actual measurements can also be used to study the interaction between the power transformer and the grid.

In this paper, an on-line TOMS for power transformers and shunt reactors is presented. Overvoltages are measured on the outside measurement terminal of bushing. The focus of the paper is on the analysis of transient overvoltages caused by lightning strikes recorded at the terminals of power transformer with rated power 150 MVA and rated voltages 220/110 kV located near thermal power plant. To determine the cause of the recorded transient overvoltages, data from TOMS are correlated with data from the LLS and from the SCADA system. Collected data about number, peak and duration of recorded transient overvoltages can be used as the basis for the assessment of the transformer insulation condition and estimation of health index. Data recorded by TOMS are also of significant importance since the insulation system of power transformer and other equipment in the substation can be damaged by lightning or switching overvoltages.

## 2. ON-LINE TRANSIENT OVERVOLTAGE MONITORING SYSTEM

Overvoltages in power network can be caused by lightning strikes to overhead transmission lines, circuit breaker switching operations and faults. Power transformers can be exposed to such transient overvoltages during the operation. Transient overvoltages with steep wave front have an impact on dielectric stresses of the insulation of first few winding turns. The number and amplitudes of overvoltages which stress the insulation depend on various parameters such as the lightning strike density in the considered area, since it determines how often the transformer is stressed by lightning overvoltages. Since the overvoltage amplitudes at transformer terminals are usually unknown, an on-line overvoltage transient recorder is used with the ability to sample, analyze and store transients in real-time. Collected data can be used as the basis for the assessment of the transformer insulation condition, especially if combined with other transformer data such as dissolved gas analysis (DGA). This fact was the driving force for upgrading the existing (TMS) transformer monitoring system [9], [10] with TOMS. Overvoltages, as well as voltages, are measured on a measuring tap of corresponding bushing. The connection with the measuring tap shown in Fig. 3 (a) is accomplished with a specially designed adaptor while the link between the adaptor and impedance matching circuit is carried out with a coaxial cable. TOMS installed on a 150 MVA power transformer is shown in Fig. 3 (b) [11], [12].

Measurement of transients needs to be triggered by an external signal. Since only one of the eight input channels of the overvoltage acquisition module can be used as a trigger, the trigger can be set only for one phase at a time. It is necessary to provide an additional signal that is used as a trigger for data acquisition. This signal shall trigger data acquisition if overvoltage occurs in any of the phases. While overvoltages are acquired occasionally, voltages need to be measured continuously in order to detect changes of bushing capacitance. To accomplish this, continuous voltage measurement is performed with an additional analogue input module. The measuring range of the overvoltage acquisition module is  $\pm 15$  V. In order to extend the overvoltage detection range to approx.  $5 \cdot \hat{U}_{fn}$  (where  $\hat{U}_{fn}$  equals to the peak value of the nominal phase voltage), it is necessary to dimension the capacitors of the matching circuit in a way that for the nominal voltage, the amplitude of the signal entering overvoltage acquisition module equals approximately 3 V. At the same time, the module used to continuously sample voltage signal has a measuring range of  $\pm 60$  V. In order to optimally utilize

both measuring ranges i.e. vertical resolution of both acquisition modules, signal conditioning was done in two stages as shown in Fig. 4.

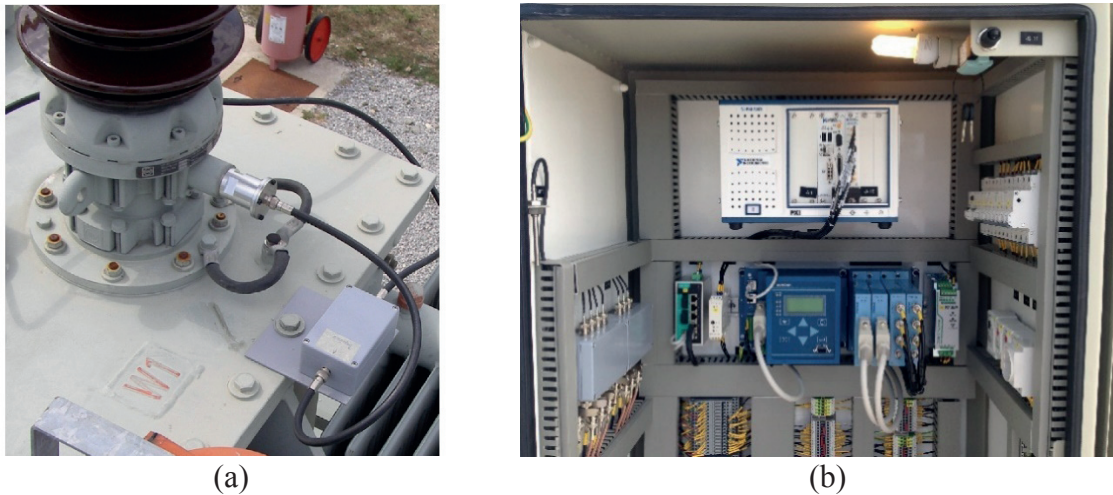

Figure 3. (a) Connection to measurement terminal of bushing; (b) Transient overvoltage monitoring system (Končar TMS+) installed on power transformer

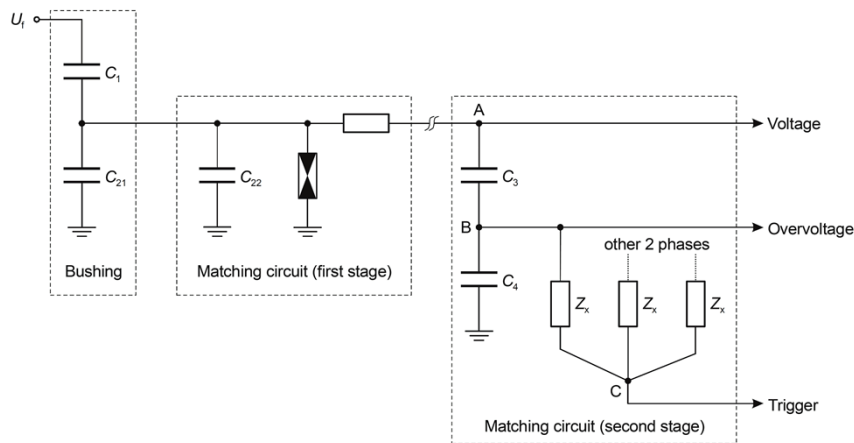

Figure 4. Scheme of matching circuit

Besides signal conditioning, the second stage of matching circuit also implements solution for the triggering of overvoltage acquisition. The following was considered during design:

- Capacitance of  $C_3$  and  $C_4$  needs to be selected to ensure that the potential of the node B is approximately 3 V when nominal voltage value  $\hat{U}_{fn}$  is applied.
- Capacitance of  $C_3$  and  $C_4$  must not influence significantly on the potential of the node A, i.e. total capacitance of  $C_3$  and  $C_4$  connected into series must be negligible in comparison to the capacitance of  $C_2$  ( $C_2 = C_{21} + C_{22}$ ). The input impedance of the voltage measuring module is 1 M $\Omega$  and it does not change the potential of the node A much.
- Impedance of the condenser  $C_4$  must be negligible at the lowest frequency (in this case system frequency of 50 Hz) to the input impedance of overvoltage module which is 1 M $\Omega$ .

The potential of the node C is used to trigger data acquisition when overvoltages occur. It is equal to 0 V as long as all the impedances  $Z_x$  are equal and the system voltage of all three phases balanced. In case of unbalance of three-phase system voltages, like it is the case when overvoltages occur, the potential of node C will not be equal to 0 V. In this way data acquisition

will also be triggered in case of a voltage disturbance in electrical grid (transients) which not necessarily have the amplitude higher than the nominal voltage. After completion of the design of the Končar TMS+ prototype and successful testing in the high voltage laboratory of Končar Electrical Engineering Institute, a project was started to install the system on in-service power transformers. TOMS is installed in the substation which is managed by the Croatian transmission system operator. Voltages are measured at 220 kV and 110 kV side of 150 MVA autotransformer AT1 with a vector group (Yna0d5). The brief layout of the 110/220 kV substation which is connected to thermal power plant is shown in Fig. 5.

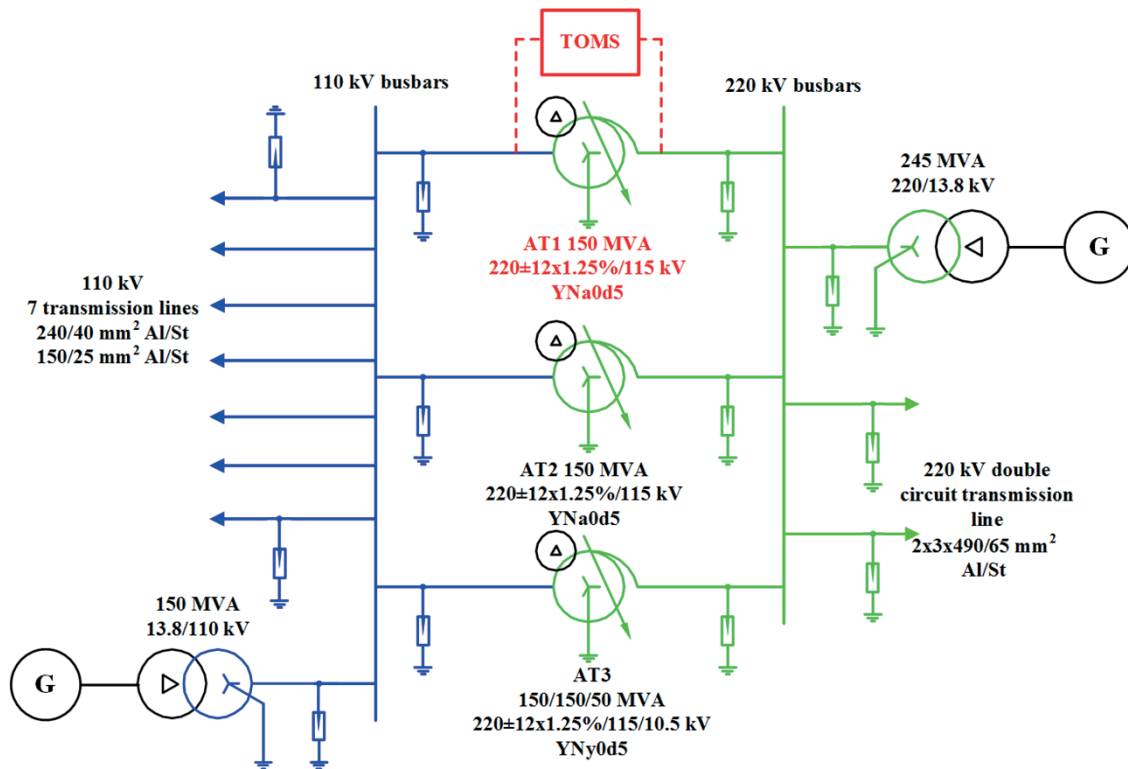

Figure 5. Layout of 110/220 kV substation connected to thermal power plant

This substation consists of three 150 MVA autotransformers, 7 transmission lines connected to 110 kV busbars and 1 double-circuit transmission line connected to 220 kV busbars. Generators located in thermal power plant are connected to 110 kV busbars via 150 MVA power transformer and to 220 kV busbars via 245 MVA power transformer. Surge arresters are installed in all transformer and transmission line bays (surge arresters with rated voltage  $U_r=198$  kV are installed at 220 kV level and with  $U_r=108$  kV at 110 kV level). All transmission lines are equipped with a single shield wire. Substation and connected transmission lines are situated in the area with relatively high lightning activity. Transmission lines are crossing over the rocky terrain with relatively high soil resistivity, some of them passing through mountainous area with relatively high tower grounding resistance. Therefore, flashovers on transmission lines often occur due to lightning strikes, leading to short circuit and automatic reclosing of circuit breakers located in transmission line bays.

### 3. LIGHTNING LOCATION SYSTEM

At the end of 2008, a LLS was established as part of the LINET network, covering a wide area of the Croatian territory. LINET is a modern LLS with a network of more than 125 sensors covering most of Europe. LLS measures the VLF/LF frequency spectrum of electromagnetic waves which lightning strikes emit. The measurement of magnetic flux is carried out through

highly sensitive sensors which are arranged across the area with spacing of around 150 to 250 km. Since the electromagnetic emission of the lightning spreads at the speed of light, it reaches the sensors at different points in time. Although the difference is in the order of micro-seconds, the exact calculation of the original emission location of the lightning strike is possible. The data measured by every single sensor is transmitted to a central server. The exact geographical position for all the lightning strikes measured is calculated and stored in a database. This measurement method is also known as the “time-of-arrival” method. Application of LLS in power system control of Croatian transmission system operator enables lightning activity tracking and time-spatial correlation with incidences (faults, automatic re-closures, outages) registered by the relay protection system [12].

#### 4. TRANSIENT OVERVOLTAGES RECORDED ON 150 MVA POWER TRANSFORMER

Several cases of recorded transient overvoltages are analysed in more detail to determine the possible cause of each event.

##### 4.1. Case 1 - lightning strike to 220 kV transmission line causing insulator flashover in one phase

Transients recorded by TOMS are shown in Fig 6. The recorded transients were time-correlated with a lightning strike which was detected by LLS. Lightning strike with current amplitude -184 kA occurred on the 220 kV transmission line route, at a distance of 62.4 km from the substation. At the same time, SCADA system detected single phase to ground fault in phase B at the 220 kV transmission line, following the single-pole auto-reclosure of circuit breaker in the line bay. Therefore, recorded transient overvoltages were most probably caused by lightning strike to transmission line which caused single phase to ground fault.

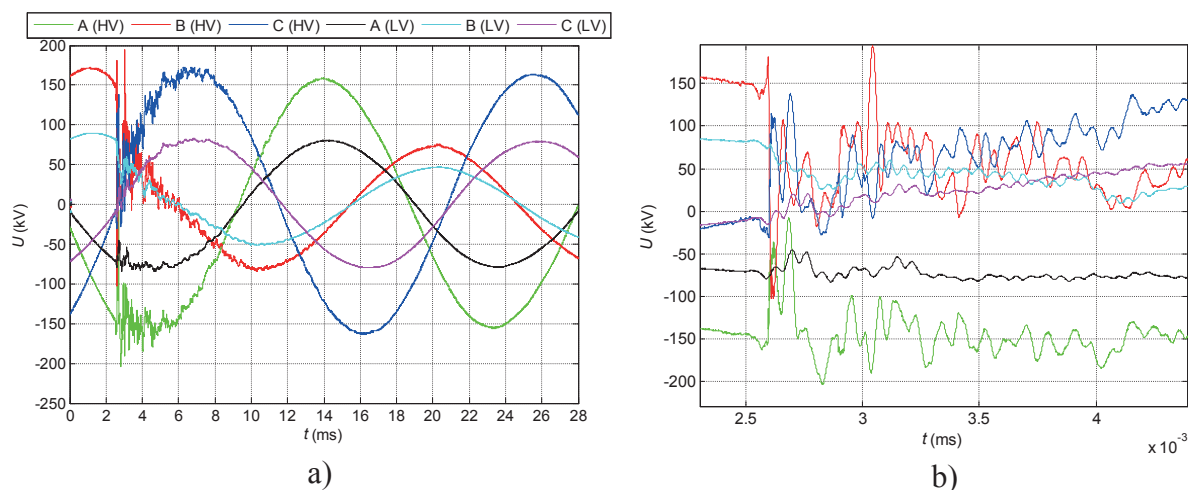

Figure 6. (a) Transients recorded by TOMS in case of lightning strike to 220 kV transmission line (b) zoomed part of transients after flashover in phase B (HV)

##### 4.2. Case 2 - lightning strike to 110 kV transmission line causing insulator flashover in one phase

Another event that was recorded by TOMS is shown in Fig 7. Second event (Fig. 7 b) occurred 113 ms after the first event (Fig. 7 a), and third event (Fig. 7 c) occurred 174 ms after the second event. Recorded transients were time-correlated with a lightning flash consisting of five subsequent lightning strikes which were detected by LLS. Parameters of multiple lightning strikes are given in Table I. Three lightning strikes marked in Table I were selected as the ones that probably caused recorded transients.

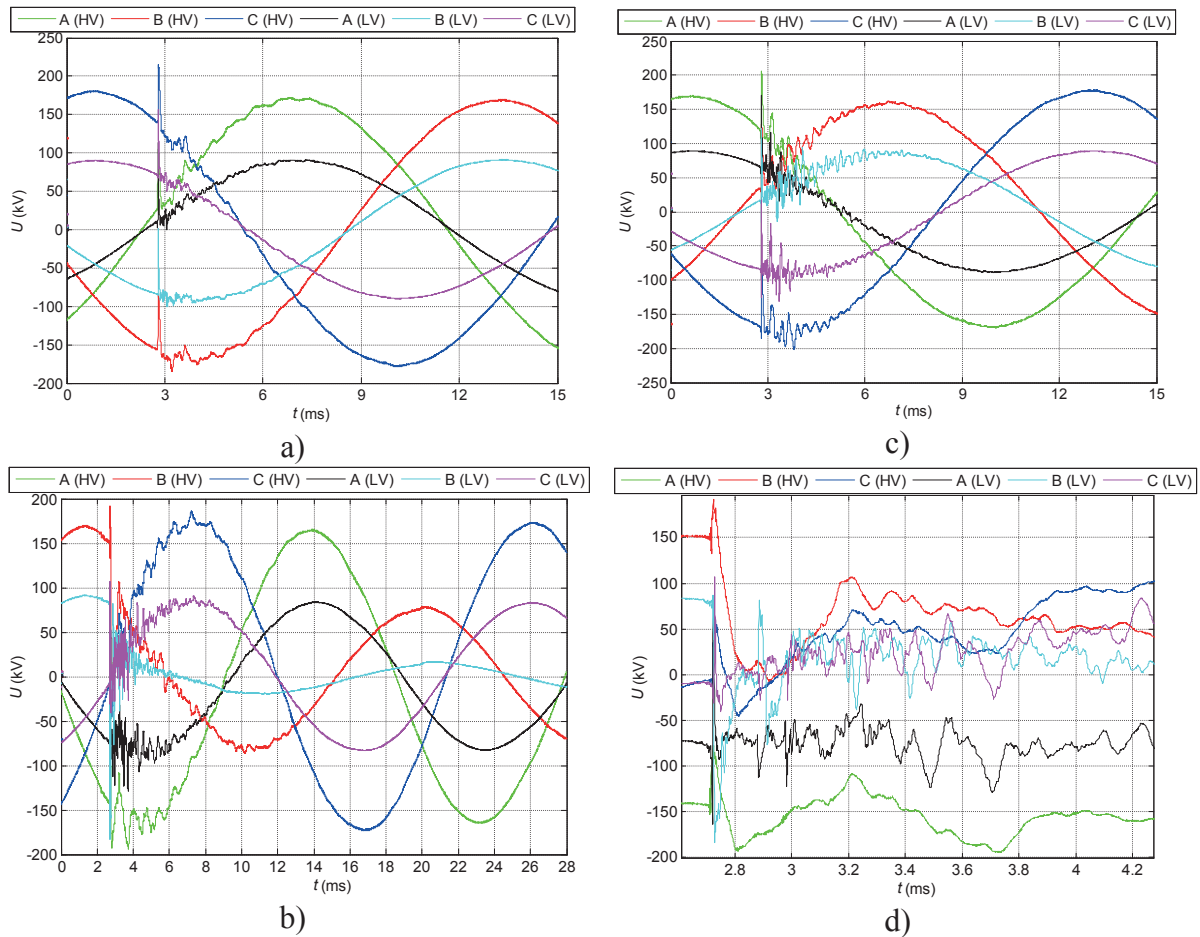

Figure 7. Transients recorded by TOMS in case of multiple lightning strikes to 110 kV transmission lines: (a) first recorded lightning overvoltage; (b) second recorded event which caused flashover in phase B (LV); (c) third recorded lightning overvoltage; (d) zoomed part of transients shown in (b) after flashover in phase B (LV)

Table I. Parameters of multiple lightning strikes detected by LLS

Lightning strike number	Time h:min:sec.milisc	Lightning current amplitude	Time difference between subsequent lightning strikes $\Delta t$
<b>1</b>	<b>22:05:21.701</b>	<b>-12.9 kA</b>	-
<b>2</b>	<b>22:05:21.814</b>	<b>-30.8 kA</b>	<b>113 ms</b>
3	22:05:21.886	-23.8 kA	72 ms
<b>4</b>	<b>22:05:21.988</b>	<b>-39.5 kA</b>	<b>102 ms</b>
5	22:05:22.098	-21.9 kA	110 ms

This was done by matching the time difference between the successive lightning strikes detected by LLS with the time difference between the events recorded by TOMS. Lightning strike occurred on the corridor of 110 kV transmission lines, at distance of 1.1 km from the substation. At the same time, SCADA system detected single phase to ground fault in phase B at the 110 kV transmission line, following by the single-pole auto-reclosure of circuit breaker in the line bay. Therefore, recorded transient overvoltages were most probably caused by multiple lightning strike in corridor of 110 kV transmission lines, which caused insulator flashover of the struck tower and consequently single phase to ground fault i.e. short-line fault in the vicinity of substation.

#### 4.3. Case 3 - lightning strike to 110 kV transmission line causing insulator flashover in all phases

Transients recorded by TOMS are shown in Fig 8.

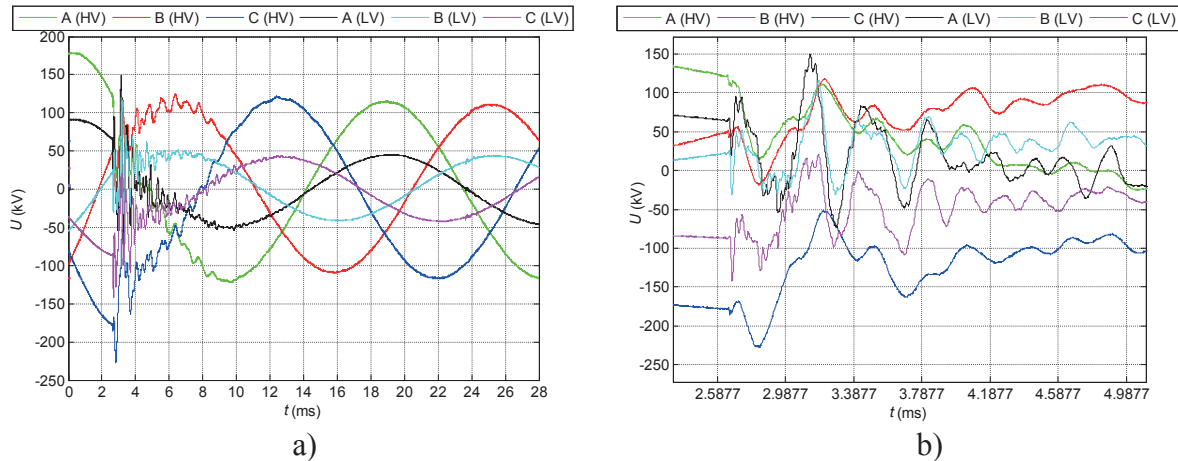

Figure 8. (a) Transients recorded by TOMS in case of multiple lightning strike to 110 kV transmission line (b) zoomed part of transients after flashover in phases A, B and C (HV)

Recorded transients were time-correlated with a lightning flash consisting of three subsequent lightning strikes which were detected by LLS. Parameters of multiple lightning strikes are given in Table II.

Table II. Parameters of multiple lightning strikes detected by LLS

Lightning strike number	Time h:min:sec.milisc	Lightning current amplitude	Time difference between subsequent lightning strikes $\Delta t$
1	19:11:22.804	6.9 kA	-
<b>2</b>	<b>19:11:22.809</b>	<b>-24.7 kA</b>	<b>5 ms</b>
3	19:11:22.834	-9.1 kA	25 ms

Lightning strike with current amplitude -24.7 kA marked in Table II was selected as the one that probably caused recorded transients. Lightning strike occurred in the corridor of 110 kV transmission line, at distance of 9.7 km from the substation. At the same time, SCADA system detected three single phase to ground faults at 110 kV transmission line, following by the three-pole auto-reclosure of circuit breaker in the line bay. Therefore, recorded transient overvoltages were most probably caused by multiple lightning strike to 110 kV transmission line, which caused insulator flashover in all phases of the struck tower and consequently simultaneous three single phase to ground faults.

#### 4.4. Case 4 - lightning strike to 220 kV transmission line causing insulator flashover in two phases

Transients recorded by TOMS are shown in Fig 9. Recorded transients were time-correlated with a lightning flash consisting of two subsequent lightning strikes which were detected by LLS. Parameters of lightning strikes are given in Table III. Lightning strike with current amplitude -169 kA marked in Table III was selected as the one that probably caused recorded transients.



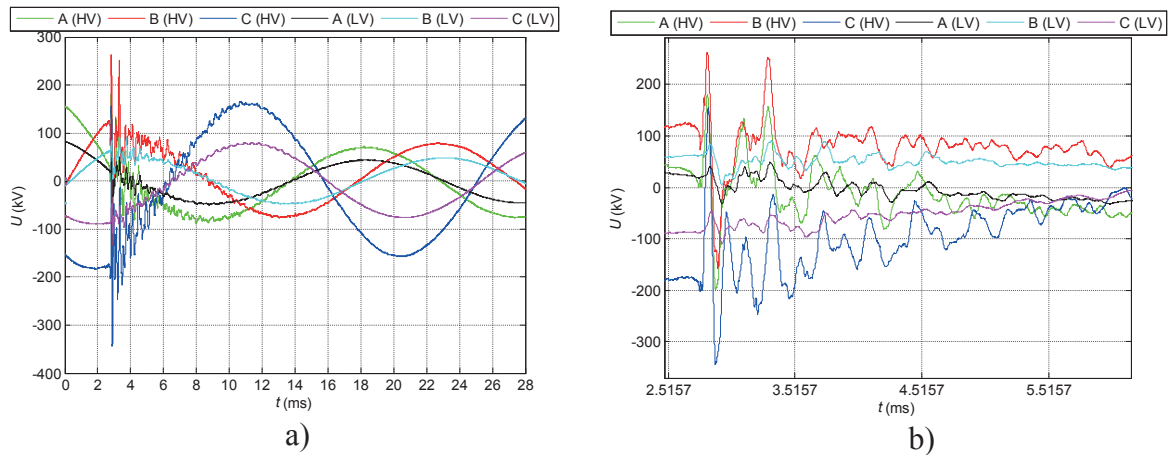

Figure 9. (a) Transients recorded by TOMS in case of lightning strike to 220 kV transmission line (b) zoomed part of transients after flashover in phases A and B (HV)

Table III. Parameters of multiple lightning strikes detected by LLS

Lightning strike number	Time h:min:sec.milisec	Lightning current amplitude	Time difference between subsequent lightning strikes $\Delta t$
1	20:03:55.864	56.3 kA	-
2	<b>20.03.55.865</b>	<b>-169 kA</b>	<b>1 ms</b>

Lightning strike occurred in the corridor of double-circuit 220 kV transmission line, at distance of 41.6 km from the substation. At the same time, SCADA system detected two simultaneous single phase to ground faults at one circuit of 220 kV transmission line, following by the auto-reclosure operation of circuit breaker in the line bay. Therefore, recorded transient overvoltages were most probably caused by lightning strike to 220 kV transmission line, which caused insulator flashover in two phases of the struck tower and consequently simultaneous two single phase to ground faults.

## 5. CONCLUSION

In this paper, an on-line TOMS for power transformers is presented that is capable to continuously record in real-time various kinds of transient overvoltages such as lightning or switching overvoltages. TOMS was used for recording lightning caused transient overvoltages at the terminals of 150 MVA power transformer located in 220/110 kV substation. Recorded waveforms originating from lightning strikes to overhead lines are correlated with data from the LLS and SCADA system. Four events recorded by TOMS were analysed to determine the possible cause of transient overvoltages appearing on the power transformer's terminals. Results show excellent time and spatial correlation between data from TOMS, LLS and SCADA system. According to the correlation between data from these systems, recorded events were most probably caused by lightning strikes to 110 kV and 220 kV overhead lines. Lightning strikes caused flashovers on the insulator strings of transmission line towers. Relay protections system successfully detected these faults and auto-reclosure of circuit breaker occurred.

In the future work, an analysis will be conducted focusing on the characteristics of recorded overvoltage waveforms, i.e. frequency and amplitude. Statistical analysis on time parameters of transient overvoltages will be performed, based on a large number of recorded events to obtain statistical distributions. Collected data about overvoltage stresses can be used as the basis for the assessment of the transformer insulation condition and estimation of health index.

## ACKNOWLEDGEMENTS

This work has been supported in part by the Croatian Science Foundation under the project “Development of advanced high voltage systems by application of new information and communication technologies” (DAHVAT).

## REFERENCES

- [1] CIGRÉ WG A2.37, “Transformer Reliability Survey”, technical brochure no. 642, Paris, 2015.
- [2] S. Tenbohlen, J. Jagers, F. Vahidi, “Standardized survey of transformer reliability: On behalf of CIGRE WG A2.37”, International Symposium on Electrical Insulating Materials (ISEIM), pp. 593-596, Toyohashi, 2017.
- [3] IEC 60060-1, “High voltage test techniques - Part I: General definitions and test requirements”, 2010.
- [4] S. Okabe, J. Takami, “Evaluation of breakdown characteristics of oil-immersed transformers under non-standard lightning impulse waveforms - method for converting non-standard lightning impulse waveforms into standard lightning impulse waveforms”, IEEE Trans. Dielectr. Electr. Insul., vol. 15, no. 5, pp. 1288-1296, 2007.
- [5] S. Okabe, “Evaluation of breakdown characteristics of oil-immersed transformers under non-standard lightning impulse waveforms - definition of non-standard lightning impulse waveforms and insulation characteristics for waveforms including pulses”, IEEE Trans. Dielectr. Electr. Insul., vol. 14, no.1, pp. 146-155, 2007.
- [6] S. Okabe, T. Tsuboi, J. Takami, “Evaluation of K-factor based on insulation characteristics under non-standard lightning impulse waveforms”, IEEE Trans. Dielectr. Electr. Insul., vol. 16, no.4, pp. 1124-1126, 2009.
- [7] P. Sun, W. Sima, M. Yang, X. Lan, J. Wu, “Study on Voltage-number Characteristics of Transformer Insulation under Transformer Invading Non-standard Lightning Impulses”, IEEE Transactions on Dielectrics and Electrical Insulation, vol. 22, no. 6, December 2015.
- [8] P. Mitra, A. De, A. Chakrabarty, “Investigation on the voltage stresses developed on transformer insulation under non-standard terminal excitations”, TENCON - IEEE Region 10 Conference, pp. 1-5, Singapore, 2009.
- [9] S. Keitoue, R. Gardijan, “Transformer Monitoring System – Important Component of Smart Grid”, ITCE, Teheran, 2014.
- [10] T. Jaković, I. Murat, F. Klarić, S. Keitoue, “Transformer Fleet Monitoring”, 4<sup>th</sup> International CIGRE Colloquium "Transformer Research and Asset Management", Pula, Croatia, 2017.
- [11] S. Keitoue, A. Keller, R. Gardijan, “Transient overvoltage on-line monitoring system for power transformers”, International Colloquium Transformer Research and Asset Management, Cavtat, Croatia, November 12 – 14, 2009.
- [12] B. Filipović-Grčić, B. Franc, I. Uglešić, I. Pavić, S. Keitoue, I. Murat, I. Ivanković, “Monitoring of transient overvoltages on the power transformers and shunt reactors – field experience in the Croatian power transmission system”, Procedia Engineering, vol. 202, pp. 29-42, 2017.