

ROBERT RAGUŽ

HEP ODS d.o.o. Zagreb,
DP „ELEKTRODALMACIJA“ Split.
robert.raguz@hep.hr

ANTE MLADINIĆ

ante.mladinic@hep.hr
HEP ODS d.o.o. Zagreb,
DP „ELEKTRODALMACIJA“ Split.

MARIO NOSIĆ

HEP ODS d.o.o. Zagreb,
DP „ELEKTRODALMACIJA“ Split.
mario.nosic@hep.hr

Technical aspect of reconstructions of 35 kV and 10 (20) kV plants with an example

ABSTRACT

At the beginning of the electrification of Dalmatia in the middle of the last century, a large number of 35/10 kV substations were built, in which 35 kV and 10 kV plants were installed inside cells (vertical partitions, so called "monijerka"). Since the substation TS 35/10 kV POSTIRA was put in operation, only the necessary repairs have been made for the maintenance of the substation. A growth in the number of consumers caused by an increasing construction of residential and commercial buildings required a reconstruction of the substation's equipment. The reconstruction of TS POSTIRA is designed in a way to maintain the existing dimensions of the premises while incorporating modern equipment with increasing strength. During the execution of the works, a special engagement of all the participants in the construction was necessary due to the reconstruction of the substation without interrupting supply of customers (part of the plant was constantly under voltage). This paper presents solutions and the method of reconstruction of TS 35/10 (20) kV POSTIRA.

KEYWORDS

Substation, Reconstruction, Stages of implementation, Primary equipment, Professional paper

INTRODUCTION

The substation 35/10 kV POSTIRA was built in 1954 with the installed power of substation 4 + 4 MVA. The building of the substation is built as a free-standing building on two floors, a ground floor and a first floor (within which the equipment is distributed), beside which are located power transformers.

Over the years, there have been substantial changes in 10 kV electrical network of the island of Brač. Primarily, reconstructions of the existing network and construction of new parts of the 10 (20) kV network were performed. By increasing the number of consumers, the load reached the power $S_{max} = 7.72$ MVA (96.5% Sn), and in the event of failure of one of transformers it was not possible to ensure the continuity of supply of all consumers, i.e. to meet the criteria n-1. Apart from the previously mentioned, the substation was technologically outdated, so a thorough reconstruction of the substation was necessary.

The reconstruction included a replacement of existing transformers (4 + 4 MVA) with transformers of (2x8 MVA) power and a replacement of 10 kV plant and measurement and protection equipment and the implementation of remote-control equipment for the substation. The 35 kV plant was not completely replaced because the existing newer vacuum switches, which replaced the old oil ones, were retained during the maintenance of the plant.

The reconstruction concept of TS (substation) is defined in a way that the entire 35 kV plant is located on the upper floor with deeper cells, while the existing busbars of 35 kV plant on the ground floor are dismantled.

After dismantling the 10 kV plant located on both floors, a new 10(20) kV plant was installed, consisting of 16 factory-fitted switch modules, located on the ground floor of the building. Due to the dimension, SF6 gas insulated switching blocks (type switching block KSMA 24 of the manufacturer Končar-EASN) have been selected.

Reconstructions of 35/10 kV substations are in fact problematic, primarily due to the fact that the work is performed while a part of plant is under voltage. For this reason, the reconstruction of the TS 35/10 kV POSTIRA has been carried out in stages with the maximum coordination of the contractors, supervisors and designers, and with special care for the implementation of the work safety.

DESCRIPTION OF THE CURRENT STATE

The existing 35 kV plant is divided on two floors. On the ground floor are 35 kV busbars, made with round Cu conductors (Ø13 mm), associated bus disconnectors and a sectional metering field.

On the upper floor are 35 kV open-type cells with vertical wall partitions and consist of seven bays:

- =H1 line bay reserve
- =H2 measurement bay
- =H3 transformer bay
- =H4 line bay Dugi Rat
- =H5 transformer bay
- =H6 line bay Nerežica
- =H7 line bay reserve



Image 1 35 kV plant

The 10 kV plant was also located on two floors, designed with single sectioned busbars on the ground floor and switchgear positioned in vertical walled partitions on the first floor. It was composed of two transformer bays, a home bay, 5 line bays and a measurement bay.

On the first floor, next to the cells of 10 kV plant, there is also a secondary equipment and protective relays of the obsolete type.

The auxiliary supply voltage is 24V =.



Image 2 10 kV plant and protective cabinets for installations before reconstruction

The layout of the ground floor and the first floor of the existing TS 35/10 kV POSTIRA is given in Images 3 and 4.

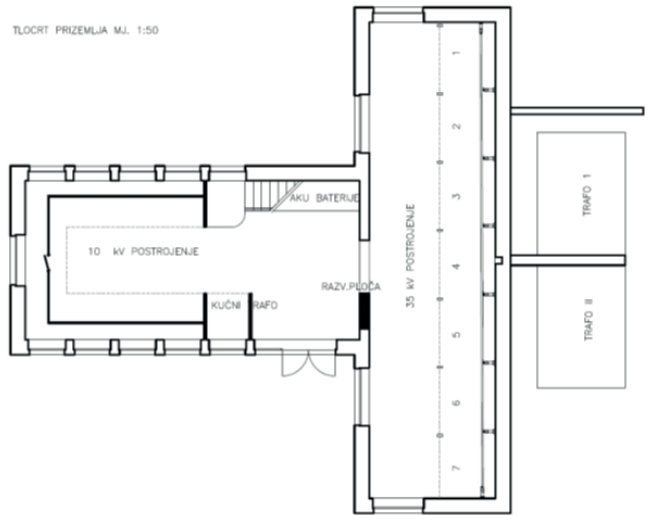

Image 3 The layout of the plant (the ground floor's plan) before reconstruction

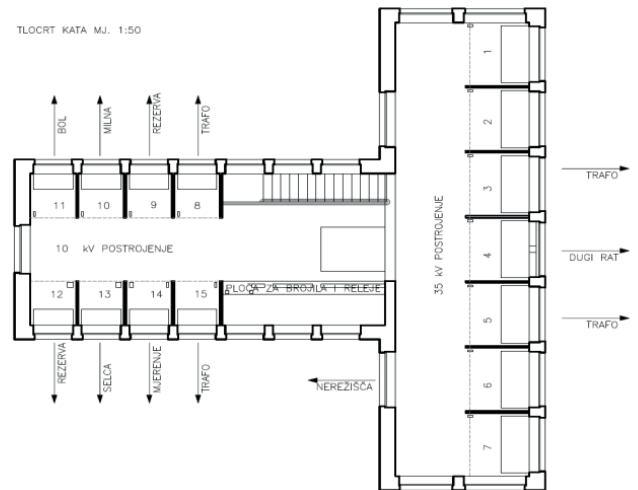

Image 4 The layout of the plant (the first floor's plan) before reconstruction

STAGES OF RECONSTRUCTION

First stage of reconstruction

Preparatory works

The work began by dismantling the home transformer and its re-installation in the already prepared concrete foundations outside the building, to ensure the supply of secondary equipment that will continue functioning until a new setting is mounted.



Image 5 Home transformer

Works on 35 kV plant

35 kV transformer bay =H5 and line bay (Nerežišća) =H6 were enclosed by insulation dividers to protect workers from accidental touching of the live parts and to safely enable the supply of transformer T2, which at this stage takes over the task of power supplying the transformer.

10 kV cables from line bays, of the section supplied by the T1 transformer, are connected by a block-joint system to line bays of the second section which will provide temporary power supply.

After the preparatory work was completed, a dismantling of old 35 kV and 10 kV non-powered plants could be commenced.

On the first floor were reconstructed 35 kV bays: measuring bay (= H2), transformer bay (= H3) and line bay TS DUGI RAT (= H4). There was an upgrade of vertical partition walls between the bays so that a depth of 220 cm was obtained, unlike the previous 180 cm. New 35 kV busbars were mounted on 35 kV support insulators on partition walls. Also, the replacement of disconnectors and current and voltage measurement transformers was performed. On the ground floor were disassembled existing busbars, bus insulators and connections between bus insulators and busbars of the unpowered part of the section.

The particularity of this work is that the two floors facility was transformed into a 35 kV plant where the complete equipment is placed on one floor, which allows a better view of the plant and facilitates the operating interventions.

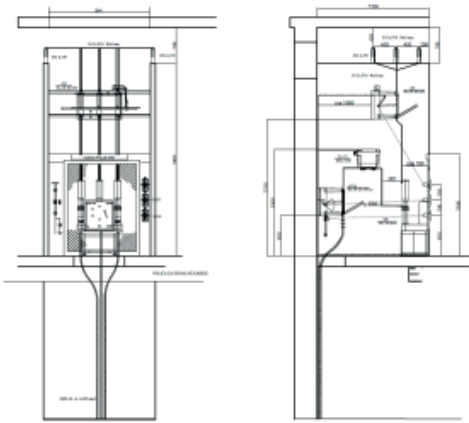

Image 6 Front view and section of 35 kV line bay after reconstruction

Works on 10(20) kV plant

After disassembling a part of 10 kV plant on the first floor, which was not powered, a safety cabinet and a remote-control system cabinet were installed.

In the floor of the ground floor, after disassembling cells of a part of the 10 kV plant, excavation of the KB channels and installation of U steel profiles were performed. In these works, it was important to level U profiles where the switch blocks 10 (20) kV were set.

The 10 (20) kV plant mounted in the first stage consists of 8 factory-fitted switchgear blocks. They were insulated with SF6 gas, rated current 1250 A, 16kA / 1s and equipped with primary and secondary equipment (terminals of bays, measuring terminals).

At this stage, switching blocks are installed:

- 1 transformer bay =J5
- 3 line bays =J1, =J2, =J3,
- 1 compensation bay =J4
- 1 measurement bay =J7
- home transformer bay =J6
- section bay =J8



Image 7 Works on the new 10(20) kV plant

Works required for reception of a power transformer

In addition to works within the building, works on the exterior of the plant have been carried out as well, including the adaptation of the transformer base for the reception of the transformer of 8 MVA power, the drainage surface, transformer oil drainage channel and oil well.

A transformer +T1 type 9NTBN 8000-38x, manufactured by Končar, was set on the adjusted base.

Connecting lines 35kV

The connecting line between the power transformer and support insulators located on the bracket-console was made of a flat copper conductor (E-Cu F 30, dimensions 40x10 mm) to which a 35 kV cable was connected (type XHE 49-A 1x185 mm², 20/35 kV) and was laid all the way to the 35 kV transformer bay (bay = H3) in built concrete channels.

Cable terminals outside the 35kV plant are the POLT-42E / 1XO-ML-5-13 and within the plant the POLT-42E / 1XI-ML-5-13«, manufacturer Raychem.



Image 8 Bracket of support insulators, surge arresters and cable terminals on a 35 kV side of the power transformer

Connecting lines 10(20) kV

Connecting line from the 10 (20) kV side of the power transformer to the support insulators located on the bracket-console was made with a flat copper conductor (E-Cu F 30, dimensions 50x10 mm) to which a 10 (20) kV cable was connected (type 3 XHE 49 1x240 mm², 12/20 kV) and was mounted up to the 10 (20) kV transformer bay (bay = J5) in built concrete channels.

Cables on both sides end with cable terminals, inside of the 35kV plant are of the type POLT-24D/1XI-ML-4-13 and outside of the plant are of the type POLT- 24D/1XO-ML-5-13, manufacturer Raychem.



Image 9 Bracket of support insulators, surge arresters and cable terminals on a 10 (20) kV side of the power transformer

Protective relays

A protection of the 35 kV bay was located centrally, in the protection on the facility's upper floor, while the protection of the 10 (20) bay of the plant is distributed on bays. Protection relays of the 10 (20) kV bay were installed on the door of the cabinet where the secondary equipment of the respective field is kept.

Protection relays are microprocessor relays, series RET 541, REF 541 and REF 543, manufactured by »ABB«.



Image 10 Protection cabinet of the 35 kV plant

Second stage of reconstruction

After completing the first stage, the built-in and tested equipment was put under voltage, thus ensuring the conditions for carrying out the work of the second stage.

The following works have been performed in the second stage:

- installation of the 35 kV transformer + T2
- reconstruction of 35 kV transformer bay (=H5) and a 35 kV line bay TS Nerežišća (=H6).
- installation of the second part of the 10(20) kV plant of 8 module switches (transformer bay = J12; line bays =J11, =J13, =J14; compensation bay = J15; measurement bay =J10; section bay = J9)
- plant for neutral point earthing

Equipment for earthing neutral points of power transformers on the 10 kV side of the substation is foreseen to start working when the network conditions are created, and until than TS POSTIRA will work with an isolated neutral point.

The particularity of this phase of reconstruction is the connection of junction bays = J9 and = J8, performed by a cable type XHE 49 3x2x (1x240/25 mm²) 20 kV mounted in a pre-built channel.

T-connectors were built in connection bays (Dual Cable Kit type D) in order to connect the cable type XHE 49 1x240 mm² (U₀ / U = 12/20 kV) to the conductor isolator of the connection bay (connector type K676LRA-P2-K-240(K)M-11-2 EUROMOLD).

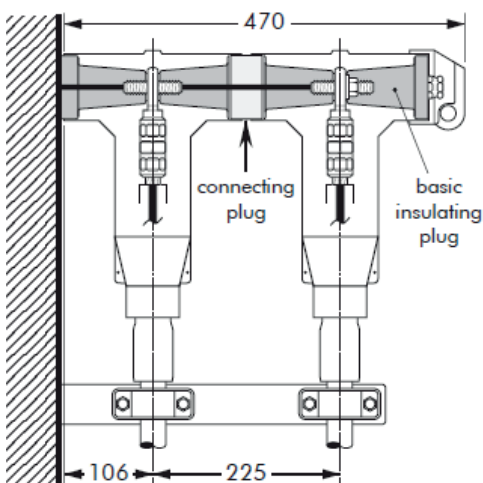

Image 11 Appearance of the connector for connecting the cable to the connection bay

Cabling

Along with works on substation POSTIRA, works on 35 kV and 10(20) kV cabling were performed.

Cabling 35 kV

The TS POSTIRA is powered in two ways: by a submarine cable from substation 110/35/10(20) kV DUGI RAT and by power line from substation 110/35 kV NEREŽIŠĆA.

The input of a cable from substation DUGI RAT is fixed in a way that the existing cable type IPHO 13 Cu 3x50 mm² in the substation circle was replaced with a new cable type XHE 49-A 1x185 mm² 20/36 kV by using a transitional cable joint type EPKJ-36B/1XU-3SB-DE 10.

A part of the 35 kV power line from the substation NEREŽIŠĆA is cabled from the last pillar in front of the TS POSTIRA up to the substation. On a 35 kV pillar, the transmission of the power cable to the cable was performed using the appropriate cable terminals and surge arresters.

The cable is placed in a cable channel up to the wall in front of the substation. In the wall of the substation, holes 150 mm in diameter have been drilled with built-in PVC pipes. The edges of the aperture were later rounded to avoid damaging cables while installing them. The cable inside the substation is mounted following the wall up to the line bay Nerežišća, on the first floor of the substation.

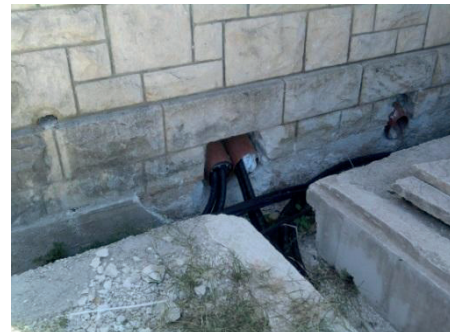

Image 12 Openings for 35 kV cables

Cabling 10(20) kV

The substation POSTIRA has three 10 (20) kV outputs, out of which one is a cable put (line bay POSTIRA) and two outputs for overhead lines (line bay NEREŽIŠĆA and line bay PUCIŠĆA).

In the area of the substation, the existing cable type IPO 13 3x150 mm² from the line bay POSTIRA was replaced by a new cable type XHE 49A 3x1x185/25 mm² and a transitional cable joint type TRAJ 24/1x120-240-3SB was built in.

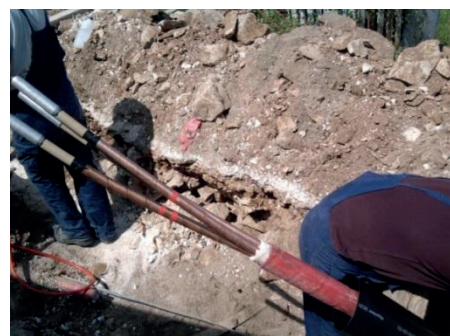

Image 13 Making of cable joint

The power line 10 (20) kV from VP NEREŽIŠĆA was cabled with a cable type XHE 49A 3x1x185 / 25 mm² to the edge of the particle where on the path of the existing power line was constructed a concrete pillar SB 1600/12, 12 m high, where the crossing from cables to power lines was installed. The pillar is equipped with a tightening console and tightening glass insulators and with a console and surge arrests HDA-12 M-NFF.

The power line 10 (20) kV from VP NEREŽIŠĆA was cabled with a cable type XHE 49A 3x1x185/25 mm² all the way to the existing wooden "A" pillar which was worn out and at the place where a new concrete pillar SB 1600/12, 12 meters high, was constructed. The pillar is equipped with a tightening console and tightening glass insulators and with a console and surge arrests HDA-12 M-NFF.

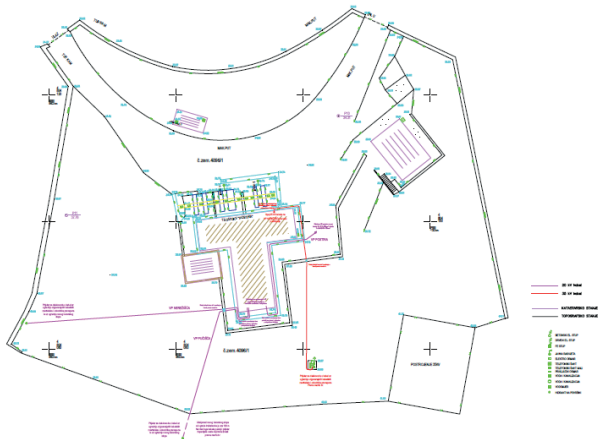

Image 14 Cabling situation

CONCLUSION

After the reconstruction of the substation TS 35/10 (20) kV POSTIRA, the criteria n-1 was satisfied. Greater reliability was ensured with modernization of 35 kV and 10 (20) kV and with the plant protection system.

When reconstructing existing buildings, a problem of predefined space is common, which often does not meet the need for new equipment. Therefore, we have to point out that for the 10 (20) kV plant were selected gas insulated blocks which are smaller in relation to the air-insulated switching blocks, thus allowing an increase of number of 10 (20) kV line bays from the existing five to the required nine (according to a single-pole scheme image 15).

After reconstruction of TS POSTIRA, a remote controlling is possible from two existing remote-control centers: a distribution center DP Elektrodalmacija Split and a Center for plant management (CUP) Brač. According to the new concept, center for plant management (CUP) will be a remote terminal of the central system in distribution center DP.

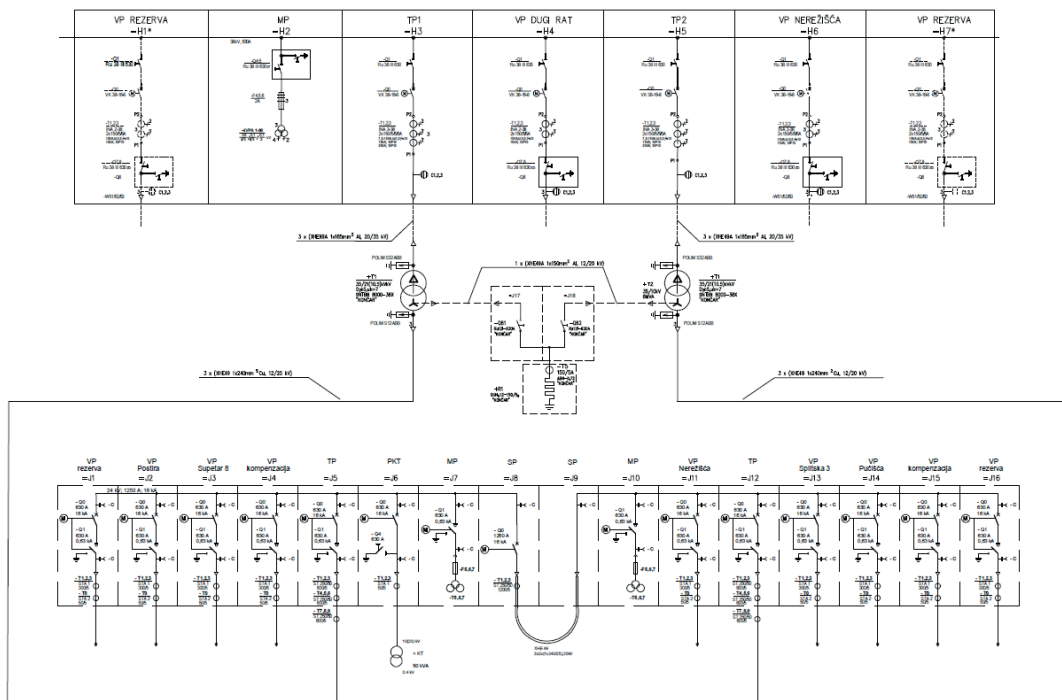

Image 15 Single pole scheme TS POSTIRA after reconstruction

LITERATURE

- Book A: Architectural-structural reconstruction project TS 35/10 (20) »POSTIRA«, project number 8438/1, project designer Mirjana Mihanović, MArch, HEP - ODS d.o.o., D.P. »Elektrodalmacija« Split, SI - Design Department:
- Book E-1-I: 35 kV and 10 (20) kV plant, voltage transformation 35/10.5kV, project number 8438/2, designer Robert Raguž, Graduate Engineer, HEP - ODS d.o.o., D.P. »Elektrodalmacija« Split, SI - Design Department:
- Book E-2-I: Auxiliary AC Power Production and Distribution System 3x380 / 220V 50 Hz and DC Voltage 110 V, Electrical Lighting and Thermal, Project Number 8438/3, Design Engineer Robert Raguž, Graduate Engineer, HEP - ODS d.o.o., D.P. »Elektrodalmacija« Split, SI - Design Department:
- Book E-3: Current Schemes, Connection Plans and Cable Lists for an Existing 35 kV Plant, Project Number 8438/4, Design Engineer Robert Raguž, Graduate Engineer.
- Book E-4: Current Schemes, Connection Plans for R1 Protection Cabinets, Project Number 8438/5, Design Engineer Robert Raguž, Graduate Engineer
- Book E-5: Power Schemes, Connection Plans and Cable Lists for the New K SMA 10 (20) kV Plant, Project Number 8438/6, Design by Robert Raguž, Graduate Engineer.
- Book E-6: Local and Remote Management System, Project Number 8438/7, Design Engineer Robert Raguž, Graduate Engineer.
- Elaboration of CABLING 35 kV and 10 (20) kV TS 35/10 (20) kV »POSTIRA, Project Number 8461, designer Robert Raguž, Graduate Engineer.