

ANALIZA VELIKOG KVARA U TRAFOSTANICI NA OTOKU KRETI

THE STUDY OF A MAJOR 2008 SUBSTATION INCIDENT IN THE EPS OF CRETE

Emmanuel Thalassinakis – Thales M. Papazoglou, Iraklio, Crete, Greece

Predmet članka je veliki kvar u elektroenergetskom sustavu Krete koji je za posljedicu imao veliku štetu na TS Iraklio 3 (150/15 kV). Problem je počeo zbog kvara na srednjem naponu u transformatorskoj stanici. Kvar nije uklonjen zbog istodobnog uništenja zaštite i kontrolnih strujnih krugova što je rezultiralo velikim strujama kratkog spoja tijekom 16 minuta, požarima na opremi i velikom štetom na visokom naponu, srednjem naponu kao i uređajima istosmjerne struje u transformatorskoj stanici, uz znatnu redukciju opterećenja. Članak počinje procjenom stanja elektroenergetskog sustava u trenutku nastanka kvara. Potom slijedi opis slijeda događaja tog kvara. Podrobno se opisuju proizašle mjere koje uključuju ponovnu uspostavu normalne opskrbe energijom, djelomičan povratak u pogon kao i konačan dovršetak popravaka na objektu transformatorske stanice. Predstavljena je analiza kvara. Doneseni su zaključci od praktične važnosti kao i preporuke u odnosu na poboljšanja u hardverskom i zaštitnom sustavu i dostupnoj tehničkoj potpori, koje mogu biti presudne za izbjegavanje i/ili ograničavanje štete kod budućih kvarova.

A major incident in the Electric Power System (EPS) of Crete resulting in extensive damages in the SS Iraklio 3, 150/15 kV is studied. The accident originated from a medium voltage fault at the substation. This fault was not cleared due to the coincident destruction of the protection and control circuits resulting in large short-circuit currents for 16 minutes, fires of materiel and extensive damage in high voltage, medium voltage as well as DC voltage hardware of the substation in addition to significant loss of load. This paper begins with an assessment of the power system condition at the time of the incident. Then the sequence of events for this accident will be described. The ensuing measures that include the restoration of interrupted power supply, the partial return to service as well as the final completion of repairs at the substation facility are detailed. The analysis of the incident is presented.

Conclusions of practical importance are drawn as well as recommendations regarding improvements in hardware and protection system and in the available technical support that can be crucial in avoiding and/or limiting damage in future incidents.

Ključne riječi: jednofazni kratki spoj; kvar u električnoj mreži; zaštita transformatorske stanice,
Keywords: power grid incident; substation protection; single-phase fault



1 UVOD

Elektroenergetski sustav Krete je otočni sustav s 1 GW instalirane snage od čega 160 MW generiraju vjetroelektrane. Vršno opterećenje u 2008. godini bilo je 650,3 MW.

Predmet proučavanja je nedavan veliki kvar na elektroenergetskom sustavu Krete koji je za posljedicu imao veliku štetu na TS Iraklio 3, 150/15 kV (2008-06-29T05:00 – nedjelja ujutro). Havarija je započela kvarom na srednjem naponu u trafostanici. Taj kvar nije bio uklonjen zbog istodobnog uništenja zaštitnih i kontrolnih strujnih krugova što je za posljedicu imalo velike struje kratkog spoja tijekom 16 minuta, požare na opremi i veliku štetu na dijelu visokog napona, srednjeg napona kao i uređaja istosmjerne struje u transformatorskoj stanici, uz znatnu redukciju opterećenja. Udjel proizvodnje iz vjetroelektrana na početku kvara bio je značajan (22,5 %). Srećom, postajala je i znatna rotirajuća rezerva (42 %) tako da je posljedično isključeno samo 10 MW vjetroelektrana.

Ova analiza počinje ocjenom stanja ili uvjeta u elektroenergetskom sustavu u trenutku nastanka kvara. Potom se opisuje slijed događaja. Podrobno su opisane proizašle mjere koje uključuju ponovnu uspostavu opskrbe energijom, djelomičan povratak u pogon, kao i konačan dovršetak popravaka na objektu transformatorske stanice. Predstavljena je analiza kvara. Doneseni su zaključci od praktične važnosti kao i preporuke u odnosu na poboljšanja u hardverskom i zaštitnom sustavu te dostupnoj tehničkoj potpori, koja mogu biti presudna za izbjegavanje i/ili ograničavanje štete kod budućih kvarova.

Operativni su podaci prikupljeni korištenjem sustava SCADA, digitalnog releja na polju prekidača 150 kV P40 (slika 1) napojnog voda za TS Iraklio 3 i digitalnog oscilografa ROCHESTER instaliranog na parnoj jedinici broj 5 – oba u termoelektrani Linoperamata, zabilježenih podataka u elektrani Athenolakos (istočni dio otoka), zabilježenih podataka na elektrani Xylokamara (zapadni dio otoka) te iz naknadnih nalaza iz TS Iraklio 3.

2 STANJE SUSTAVA NETOM PRIJE KVARA

Srećom, u trenutku incidenta, potražnja je bila relativno niska i iznosila je 312 MW (gotovo minimalno opterećenje) za cijeli otok. TS Iraklio 3 je bila opterećena sa 20 MW. Svaki od dva transformatora (svaki nominalne snage 50 MVA) transformatorske stanice bili su opterećeni s 8 MW, a

1 INTRODUCTION

The power system of Crete is an island system with 1 GW installed power out of which 160 MW are wind-power generation. It had a 650,3 MW peak demand in year 2008.

A recent major incident in the Electric Power System (EPS) of Crete resulting in extensive damages in the SS Iraklio 3, 150/15 kV (2008-06-29T05:00 – Sunday morning) is studied. The accident originated from a medium voltage fault at the substation. This fault was not cleared due to the coincident destruction of the protection and control circuits resulting in large short-circuit currents for 16 minutes, fires of materiel and extensive damage in high voltage, medium voltage as well as DC voltage hardware of the substation in addition to significant loss of load. There was substantial wind power penetration at the incident start (22,5 %). Fortunately, there was also substantial spinning reserve in parallel (42 %) so only 10 MW of wind were switched-off as a result.

In this Presentation we begin with an assessment of the power system condition at the time of the incident. Then the sequence of events for this accident is described. The ensuing measures that include the restoration of interrupted power supply, the partial return to service as well as the final completion of repairs at the substation facility are detailed. The analysis of the incident is presented. Conclusions of practical importance are drawn as well as recommendations regarding improvements in hardware and protection system and in the available technical support that can be crucial in avoiding and/or limiting damage in future incidents.

Operational data were collected using the SCADA system, the digital relay at the 150 kV bay of the breaker P40 (Figure 1) of the feeder for the SS Iraklio 3 and the digital oscillograph ROCHESTER installed at the steam unit #5- both at Linoperamata power station, data registrations at the Athenolakos power station (east part of the island), data registrations at the Xylokamara power station (west part of the island), and from post-mortem findings at the SS Iraklio 3.

2 SYSTEM STATE JUST BEFORE THE INCIDENT

Fortunately, at the time of the incident the demand was relatively low and amounted to 312 MW (near minimum load) for the whole island. There was a load of 20 MW from Iraklio 3 substation. Each of the two transformers (nominal power of 50 MVA

preostalih 4 MW dolazilo je izravno iz vjetroparka Domiki Kritisa i napajalo je 15 kV sabirnice putem prekidača P270 (nije prikazan na slici 1).

each) of the substation were loaded with 8 MW, and the remaining 4 MW came directly from the Wind Park of Domiki Kritisa fed to the 15 kV busbars via the breaker P270 (not shown in figure).

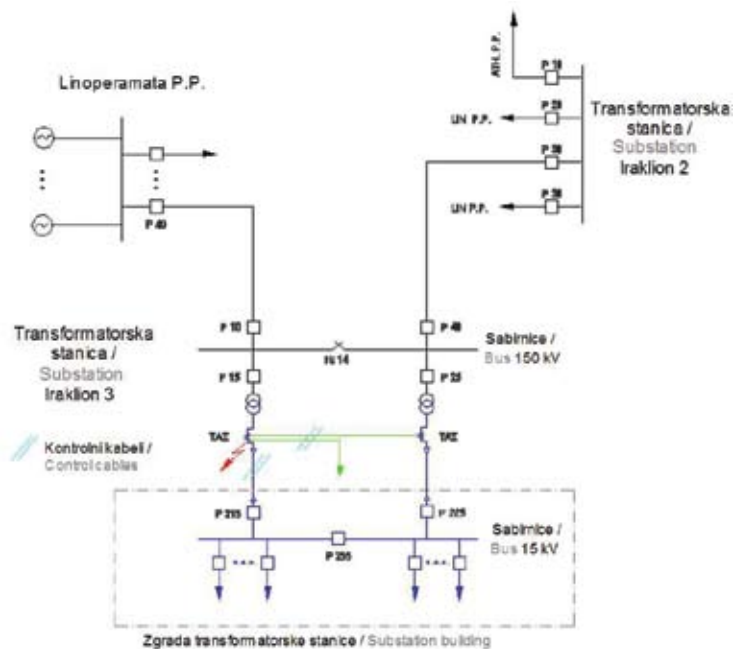

Slika 1 — Jednopolna shema TS Iraklion 3 s veznim stanicama
Figure 1 — Single-line diagram of SS Iraklion 3 with connecting stations

Zbog vremena u danu i očekivanog porasta opterećenja, postojala je znatna rotirajuća rezerva u trenutku incidenta koja je iznosila 138 MW (44,2 % od opterećenja), uz činjenicu da su jedinice koje su bile u pogonu u tom trenutku imale dovoljno kapaciteta za proizvodnju jalove snage. To je djelovalo povoljno i smanjilo je utjecaj kvara na opskrbu energijom (slika 2). Udjel vjetroelektrana stao je na 23 %. Bazne parne jedinice bile su u pogonu u tom trenutku kao i dizelske jedinice.

Due to the hour and the expected load increase, there was substantial spinning reserve at the time of the incident amounting to 138 MW (44,2 % of load demand), plus the fact that the units operating at the time had ample capacity for reactive power generation. This had been favorable and it reduced the overall impact of the incident on the load supply (Figure 2). The wind power penetration stood at 23 %. There were steam base units operating at the time and diesel units as well.

3 SLIJED DOGAĐAJA ZA VRIJEME KVARA

3 THE INCIDENT SEQUENCE OF EVENTS

Crvene strelice na slici 1 pokazuju mjesto kvara. Kvar je očito počeo kao jednofazni kratki spoj koji se zbog posljedičnog uništenja dijela zaštite u 24 sekunde razvio u trofazni kratki spoj (slika 3).

The red arrows in Figure 1 show the position of the fault. The fault apparently started as a single-phase fault which due to the resulting destruction developed in 24 seconds into a three-phase fault (Figure 3).

Na slici 2, različite boje, odozdo prema gore, odgovaraju parnim jedinicama, kombiniranom ciklusu, dizelskim jedinicama, plinskim turbinama i vjetroelektranama.

In Figure 2, different colors, from base upwards, correspond to steam units, combined cycle, diesel units, gas turbines, and wind generation.

U kritičnom razdoblju došlo je do pada napona na visokonaponskim sabirnicama TS Iraklio 3 na

In the critical period there was a voltage drop at the HV busbars of SS Iraklio 3 to 130,61 kV, while at Ath-

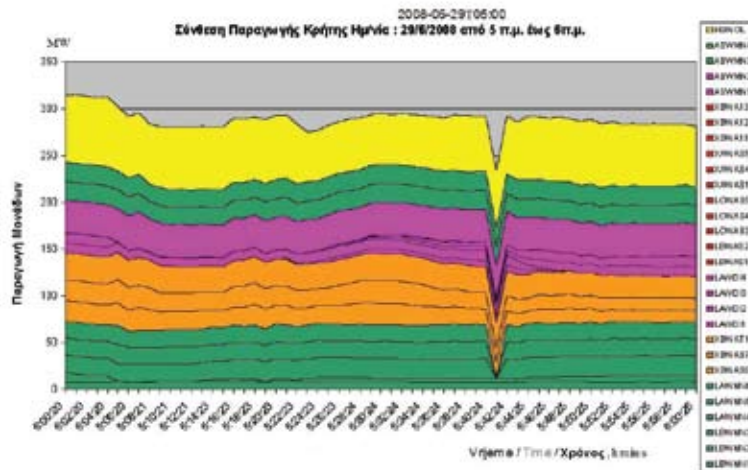

Stika 2 — Opskrba opterećenjem (vremenski graf u h:min:s) uključujući i poremećaj po incidentu
Figure 2 — Load supply (time-graph in h:min:s) including the incident disturbance

130,61 kV, dok je u Atherinolakosu (zapadna strana otoka) pao na 143 kV gdje je parna jedinica broj 1 (nominalne snage 50 MW) proizvodila 20 MW i 0,74 Mvar prije kvara – porasla je na 42,2 Mvar nakon kvara i kasnije se ustalila na 20 Mvar. Mogućnost proizvodnih jedinica da povećaju proizvodnju jalove snage pomogla je održanju prihvatljivih razina napona i tako je izbjegnuto opći raspad. Na slici 3 se mogu vidjeti linijski naponi kod jedinice Atherinolakos broj 1 kao i proizvodnja djelatne i jalove snage u vremenu oko kvara.

Na slici 4 može se vidjeti proizvodnja jalove snage dvije plinske turbine u postrojenju kombiniranog ciklusa Xylokamara (istočna strana Krete). Ponovno se može vidjeti povećanje proizvodnje jalove snage u kritičnom razdoblju – koje je išlo gotovo od 0 Mvar na 23,145 Mvar i 22,998 Mvar za pojedinu plinsku turbinu.

Na slici 5 može se vidjeti napon i frekvencija izmjereni na TS Iraklio 2. Vidi se da je na početku kvara, zbog gubitka dvije jedinice (parne jedinice broj 3 Linoperamata sa 7 MW opterećenja, i dizelske jedinice broj 4 Linoperamata s 10,5 MW opterećenja), frekvencija pala na minimum od 49,53 Hz.

Ukupna neisporučena energija radi podfrekvencijske zaštite (u razdoblju između 21. i 25. min) iznosila je 7,6 MWh.

Neisporučena energija zbog kvara na TS Iraklio 3 iznosila je 46,6 MWh. Prekid opskrbe potrošača trajao je između 2 sata i 45 minuta do maksimalno 3 sata i 32 minute.

erinolakos (west-side of the island) fell to 143 kV where the steam unit #1 (nominal power 50 MW) was generating 20 MW and 0,74 Mvar before the incident – went up to 42,2 Mvar after the incident and leveled-off at 20 Mvar later. The capacity of the units to increase their reactive generation helped in sustaining voltage levels acceptable and to avoid a general blackout. In Figure 3 we can see the line-voltages at the Atherinolakos unit #1 as well as the real and reactive power generation around the incident.

In Figure 4 we can see the reactive power generation of the two gas turbines of the combined-cycle unit at Xylokamara power station (east-side of Crete). Again we see the increased reactive power generation at the critical period, which increased from close to 0 Mvar before the incident to 23,145 Mvar and 22,998 Mvar for each turbine.

In Figure 5 we can see the voltage and the frequency measured at the SS Iraklio 2. We see that at the beginning of the incident, because of the loss of two power units (steam unit #3 Linoperamata with 7 MW load, and Diesel unit #4 Linoperamata with 10,5 MW load), the frequency dropped to a minimum of 49,53 Hz.

We note that the total energy loss due to underfrequency-protection load shedding (lasting from 21 to 25 min) amounted to 7,6 MWh.

The energy lost due to the destruction of SS Iraklio 3 amounted to 46,6 MWh. The power cuts to consumers lasted from 2hrs 45 min up to 3hrs 32 min maximum.

Figure 5

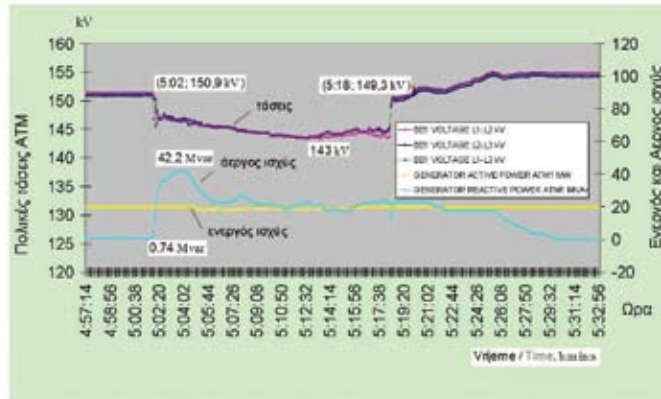

Slika 3 – Linijski naponi, djelatna i jalova snaga parne jedinice 1 u elektrani Atherinotakos
 Figure 3 – Line voltages, real and reactive power of steam unit 1 – Atherinotakos PS

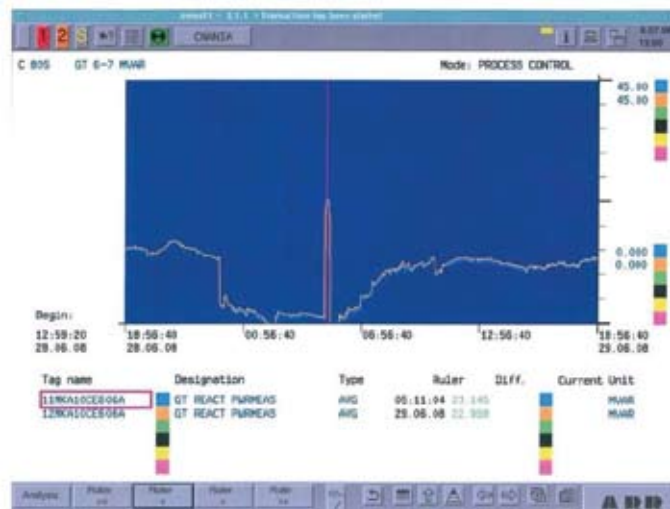

Slika 4 – Jalova snaga plinskih turbina u postrojenju kombiniranog ciklusa u Xylokamari
 Figure 4 – Reactive power of GTs of Combined cycle unit at Xylokamari

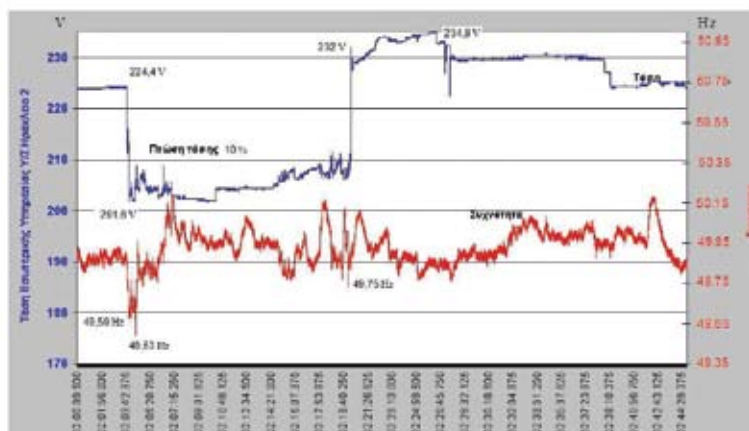

Slika 5 – Vremenski grafovi napona i frekvencije izmjereni na TS Iraklio 2
 Figure 5 – Voltage and frequency time-graphs measured at Iraklio 2 substation

4 ANALIZA DOGAĐANJA

Istraga nakon događaja pokazala je da je kvar počeo kao jednofazni kratki spoj srednjenaponskog kabela koji je povezivao sekundar prvog transformatora TS Iraklio 3, samo od točke podzemnog ulaska kabela. Bio je to kvar visokog otpora za koji se zna da ne uključuje diferencijalnu zaštitu transformatora. Zbog topline koju je proizveo kvar, izgorjele su izolacije niskonaponskih kabela zaštite čvorišta kondenzatora koji su bili u blizini te je stoga srednji napon bio prenesen na polje kondenzatora uzrokujući potpuno uništenje zbog topline i požara. Osim toga, srednji napon je prenesen na sve zaštitne i kontrolne krugove transformatorske stanice.

Ubrzo nakon toga kvar se razvio u trofazni kratki spoj i izazvao da diferencijalna zaštita transformatora otvori prekidač P215 (slika 1) na sekundarnoj strani transformatora, no nije uspjela otvoriti prekidač P15 (ista slika) zbog uništenja pripadajućeg okidača strujnog kruga. Drugim riječima, kvar nije bio uklonjen. Procjenjuje se da su struje kratkog spoja iznosila 4 933 A. Te su struje tekle neprekidno 16 minuta, stvarajući destruktivnu toplinu koja je rezultirala raširenim požarom na instalacijama transformatorske stanice. Krajnji je rezultat bila značajna šteta na energetskom transformatoru broj 1 transformatorske stanice, te uništenje sve kontrolne i zaštitne opreme, uključujući jedan interni transformator za servisni napon, tri audio-frekvencijska transformatora, itd.

5 PREPORUKE

Poukom ovog iskustva, smatra se obaveznim odvojiti energetske kabele od kontrolnih i zaštitnih kabela provodeći ih kroz potpuno različite kanale. Također, savjetuju se povratne zaštite (engl. back-up) transformatora. Na primjer, trebala bi postojati povratna zaštita u slučaju da diferencijalna zaštita ne djeluje. Stoga bi trebalo uvesti nadstrujnu zaštitu, uz nešto veći vremenski interval, na visokonaponskom prekidaču transformatora. Nadalje, bila bi nužna zaštita od zemljospoja koja je osjetljivija na jednofazne kratke spojeve.

Također, smatra se nužnim dodatno istražiti učinkovitost rada digitalnih distantnih releja korištenih u sustavu.

4 THE ANALYSIS OF WHAT HAD HAPPENED

From the post-mortem on-site investigation it became apparent that the fault began as a single-phase MV cable fault connecting the secondary of the first transformer of SS Iraklio 3, just 5 m away from the point of the subterranean entrance of the cable. It was a high resistance fault that is known not to energize the transformer differential protection. Due to the heat produced by this fault, the LV cables of the capacitor node-protection, which were in the vicinity, had their insulations burnt, and therefore the MV was transmitted to the capacitor bay causing complete destruction due to heat and fire. In addition the MV had been transmitted to all the protection and control circuits of the substation.

Shortly afterwards, the fault developed into a three-phase fault causing the differential transformer protection to open the circuit breaker P215 (Figure 1) on the transformer secondary side, but, it failed to open the breaker P15 (same figure) due to the destruction of the corresponding trip-circuit. In other words, the fault failed to be cleared. The fault currents have been estimated to 4 933 A. These currents were sustained for 16 continuous minutes, producing destructive heat that resulted in extensive fires in the substation installations. The end result was that Power Transformer # 1 of the substation suffered extensive damage, as had all the control and protection equipment, including one internal service transformer, three audio-frequency transformers, etc. which were destroyed.

5 RECOMMENDATIONS

Following this experience, it is considered a must to separate the power cables from the control and protection cables passing them through completely different channels. Moreover, back-up transformer protections are advisable. For example, there should be a back-up protection in case differential protection fails to act. So, a high-current protection should be enacted, at a slightly higher time-interval, at the HV breaker of the transformer. In addition, a restricted earth-fault protection could be necessary, which is more sensitive to single-phase faults.

A further investigation of the effectiveness of operation of the digital distance relays, used in the system, is also deemed necessary.

6 ZAKLJUČCI

Opisan je težak kvar u radu elektroenergetskog sustava Krete 2008. godine. Kvar je izazvao veliku štetu na TS Iraklio 3, znatan poremećaj rada i prekid u opskrbi energijom. Predstavljena je analiza slijeda i uzroka događaja. Iznesene su preporuke u smislu pouzdanijeg rada i izgradnje postrojenja.

6 CONCLUSIONS

A destructive incident in the operation of the electric power system of Crete in 2008 has been presented. The fault caused extensive damages at the SS Iraklio 3, substantial disruption of service, and loss of energy delivery. An analysis of what and how it happened was presented. Recommendations were drawn for practical as well as design purposes.

LITERATURA / REFERENCES

- [1] THALASSINAKIS, E., PAPAZOGLU, M. T., The Study of a Major 2008 Substation Incident in the EPS of Crete, Iraklio, 2008
-

Adrese autora:

Prof. Dr.Sc. **Thales M. Papazoglou**
tmpapa@teiher.gr
thales@teemail.gr

Laboratorij elektroenergetike (EPSL)
Tehnološko-obrazovni institut Krete (TEIC)
P.P. 1427
710 01 Iraklio
Kreta, Grčka
Emmanuel Thalassinakis
DEH - Grčka

Authors' Addresses:

Professor **Thales M. Papazoglou**, PhD
tmpapa@teiher.gr
thales@teemail.gr
Electric Power Systems Lab (EPSL)
The Technological Educational Institute of Crete (TEIC)
P.O. Box 1427
710 01 Iraklio
Crete, Greece
Emmanuel Thalassinakis
DEH - Greece

Uredništvo primilo rukopis:
2009-03-27

Prihvaćeno:
2009-04-17

Manuscript received on:
2009-03-27

Accepted on:
2009-04-17