

Detailed Transients Simulation of a Doubly Fed Induction Generator Wind Turbine System with the EMTP-Type OVNI Simulator

Mažana Lukić Armstrong*
University of British Columbia
Canada

José R. Martí

Prabha Kundur
University of Toronto
Canada

SUMMARY

Doubly fed induction generator wind turbines are increasingly used in new wind turbine installations all over the world. Growing concerns about the impact of a large number of these generators on transient and voltage stability of power system networks has led engineers to revisit modelling and simulation practices used for system stability analyses. In this paper, the latest advancements in design of the general purpose power system simulator OVNI developed at the University of British Columbia are presented, and its application to the simulation of a doubly fed induction generator (DFIG) wind turbine system is shown. Because OVNI is based on the EMTP methodology for accurate detailed modelling, and the Multilevel MATE (Multi-Area Thévenin Equivalent) concept, which, combined with hardware solutions, allows for fast simulation of large power system networks, it represents an ideal tool for testing and developing benchmark models of different wind turbine installations. Using the EMTP approach for modelling of a DFIG wind turbine system and its feeding power network we were able to study the responses of the wind turbine generator to different network events. The ultimate goal of our investigations is the development of a benchmarking process for testing different models of wind turbine generators and determining the range of validity of various degrees of approximations normally used for stability simulation purposes. Due to the rapid development of wind generation technology, it is essential to determine the minimum requirements for dynamic modeling of wind turbine generators for assessing impacts of their installations on the dynamic security and stability of power systems.

KEYWORDS

power systems – EMTP – modelling – simulations – stability – wind turbine generators (WTG) – doubly fed induction generator (DFIG)

*mazanal@ece.ubc.ca

1. INTRODUCTION

The Object Virtual Network Integrator (OVNI) is a simulation tool aimed at obtaining very fast, real-time solutions of power system networks [1], [2], [3]. OVNI is based on the EMTP program (Electromagnetic Transients Program) used to simulate electromagnetic transients [4]. OVNI is built around the MATE ("Multi-Area Thévenin Equivalent") network partitioning framework [1] that extends the main ideas of Diakoptics [5] by recognizing that the subsystems split by the branch links can be represented by Thévenin Equivalents. The multilevel MATE concept [6] further extends the concept of MATE and provides a computationally efficient solution framework for the inclusion of controllers and non-linear elements, as well as power system components such as phase-domain synchronous and induction machines.

The advantages of the detailed modelling and simulation of DFIG wind turbine generators (WTG) with OVNI include: (1) three-phase representation allowing for accurate simulation of balanced and unbalanced network conditions; (2) phase-domain full-detail machine modelling, including the modelling of torsional shaft oscillations; (3) simultaneous solution of the WTG control systems and network equations; (4) and phase-domain modelling of power electronic voltage source inverters. This paper will demonstrate how an experimental DFIG wind turbine system from [7] is modelled in OVNI with the full time-domain (EMTP-type) solution.

2. DOUBLY FED INDUCTION GENERATOR WIND TURBINES

Variable-speed turbines with doubly fed induction generators have become a new standard for wind turbines of installed capacity above 2 MW. As the ratings of such wind farms connected to the power system grid become closer to the ratings of traditional generating units, and their share in the total installed generating capacity of the power system becomes considerable, it becomes necessary to perform studies of the impact of large wind farm connections to the power system network. The main concern is to study the responses of wind farms to power system faults and their impact on overall system stability.

Variable-speed operation of the turbines is achieved through the use of power electronic converters that can also be used to improve the grid integration aspects. It is anticipated that in the future it may be possible to require specific responses of wind farms to network disturbances from the manufacturers to help in the system recovery. Detailed model parameters of converter-controlled wind turbines can only be provided by manufacturers, and these control details are usually confidential and not readily available. However, efforts are being made to create reasonably accurate general models of doubly fed induction generators that can produce realistic results of wind farm responses to system disturbances and the influence of the associated controls.

Physically, the machine of a doubly fed induction generator is a conventional wound rotor induction machine. The key distinction is that this machine is equipped with a solid-state AC excitation system. The AC excitation is supplied through an AC-DC-AC voltage converter. Doubly fed induction machines have a significantly different dynamic behaviour than conventional synchronous or induction machines. The fundamental frequency electrical dynamic performance of a doubly fed induction generator is completely dominated by the field converter. Conventional aspects of the generator's performance related to the rotor angle, excitation voltage and synchronism are largely irrelevant. The electrical behaviour of the generator and converter is that of a current-regulated voltage-source inverter. The converter makes the wind-turbine behave like a voltage behind a reactance that produces the desired active and reactive current delivered to the device terminals. A schematic of a doubly fed wind turbine system with two voltage-source inverters and accompanying controls is depicted in Figure 1.

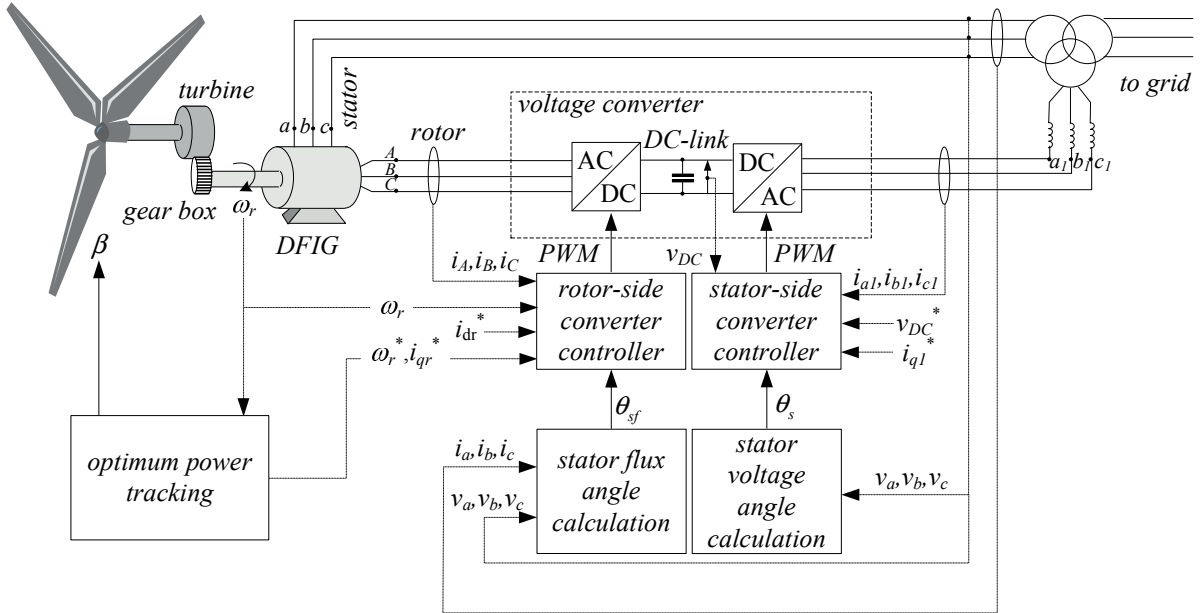

Figure 1. Schematic of a doubly fed induction generator wind turbine system

3. DFIG MODEL STRUCTURE

To construct a DFIG wind turbine system model, the following structure is considered:

- A doubly fed induction generator model based on a phase-domain induction machine model
- A voltage converter model based on an average model of a back-to-back PWM voltage-source inverter with stator and rotor-side converter control
- A wind model that maps the wind speed to the shaft mechanical power for the turbine
- A crowbar protection scheme
- Mechanical controls, including blade-pitch control and over/under speed trips

A doubly fed induction generator can be modelled as an induction machine in phase coordinates [8]. A phase-domain induction machine model is especially convenient for the implementation in the EMTF-type of simulators such as OVNI because it can be naturally interfaced with a three-phase network representation. The phase-domain model can be simulated more efficiently, with time steps in the order of milliseconds, than the commonly used EMTF dq0 model. The difference between a conventional induction machine and a doubly fed induction machine is that the rotor of a doubly fed induction machine is connected to the grid via a voltage converter. The electrical equations of the two machines are identical and in the general form, for discretization with the trapezoidal rule, are shown in (1):

$$\begin{bmatrix} \mathbf{e}_{abc} \\ \mathbf{e}_{ABC} \end{bmatrix} = \begin{bmatrix} \mathbf{R}_s & 0 \\ 0 & \mathbf{R}_r \end{bmatrix} + \frac{2}{\Delta t} \begin{bmatrix} \mathbf{L}_s & \mathbf{L}_{sr} \\ \mathbf{L}_{sr}^T & \mathbf{L}_r \end{bmatrix} \begin{bmatrix} \mathbf{i}_{abc} \\ \mathbf{i}_{ABC} \end{bmatrix} + \begin{bmatrix} \mathbf{e}_{habc} \\ \mathbf{e}_{hABC} \end{bmatrix} \quad (1)$$

where \mathbf{e}_{abc} and \mathbf{e}_{ABC} represent vectors of stator and rotor voltages across the windings, \mathbf{R}_s and \mathbf{R}_r are diagonal matrices of stator and rotor winding resistances, \mathbf{L}_s , \mathbf{L}_{sr} and \mathbf{L}_r are matrices of stator and rotor windings self and mutual inductances, and \mathbf{e}_{habc} and \mathbf{e}_{hABC} represent vectors of stator and rotor windings history voltages. A discrete phase-domain induction machine electrical model is depicted in Figure 2.

With respect to the mechanical equations, detailed modelling of DFIG wind turbines requires a two-mass shaft representation. When analyzing the system response to heavy disturbances (such as

short circuits in the network), the generator and turbine acceleration can be simulated with sufficient accuracy only if shaft oscillations are included in the model.

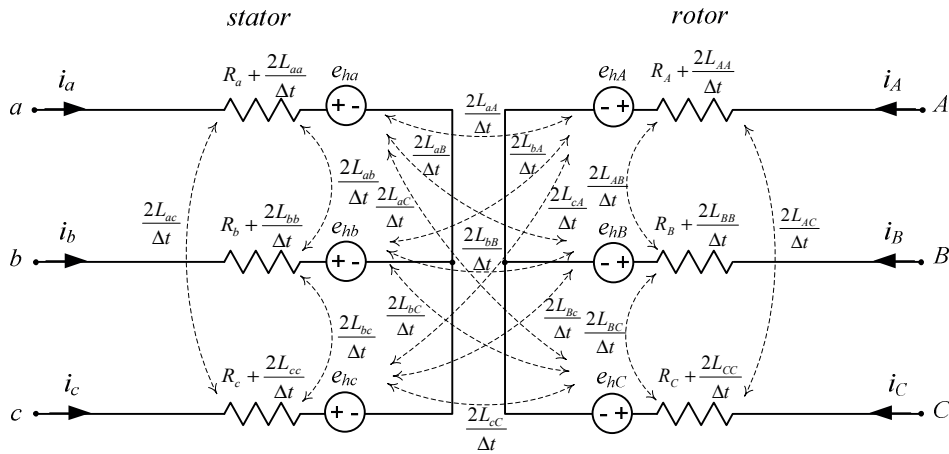

Figure 2. Discrete phase-domain induction machine electrical model

The converter and its controls highly influence the dynamic response of a DFIG. The voltage converter that supplies the rotor of a doubly fed induction generator consists of two voltage-source inverters linked via a DC-link capacitor, as shown in Figure 1. The stator-side voltage-source inverter is connected to the network and to the DFIG stator terminals. The rotor-side voltage-source inverter is connected to the DFIG rotor circuit. The approximate fundamental frequency modelling approach of PWM converters (average model) neglects all switching operations occurring within the voltage-source inverters and represents the converter as an ideal, lossless DC-to-fundamental-frequency AC converter. The high-frequency ripple due to switching harmonics caused by the PWM operation of the voltage converter is of little significance for studying the performance of DFIG WTG in response to network events [9], and in practice is small and further limited by the inclusion of supply-side inductors [7]. In this study, the average model of a PWM converter is implemented in OVNI in phase coordinates. A more complex and detailed model of a PWM converter could be used as well. However, high frequency switching would require the model to be solved with smaller discretization time steps than the one used in the test case described in this paper. The concept of Multilevel MATE [6] allows a common simultaneous solution of power system networks and components modelled individually with different size discretization time steps (latency exploitation) [10].

Rotor- and stator-side converters are vector controlled in the stator flux- and stator voltage-oriented dq reference frame, respectively. Vector control of the stator-side converter enables decoupled active and reactive power control at the machine's terminals, maintaining the converter's DC voltage at the set value. Vector control of the rotor-side converter enables decoupled control of electrical torque, and therefore rotor speed, used for extracting optimum power available from the wind (optimum power tracking). Algorithms for the calculation of stator flux and stator voltage positions are based on the instantaneous values of fundamental frequency stator flux linkages and phase voltages. For the stator-side converter control the angular position of the stator voltage (θ_s) can be calculated from the instantaneous values of stator voltages (v_a , v_b and v_c) as:

$$\theta_s = \tan^{-1} \left(\frac{\frac{\sqrt{3}}{2} v_b - \frac{\sqrt{3}}{2} v_c}{v_a - \frac{1}{2} v_b - \frac{1}{2} v_c} \right) \quad (2)$$

The objective of the tracking control is to keep the turbine speed fixed to the optimum power curve as the wind velocity varies. For wind velocity higher than the turbine's rating, the turbine energy captured has to be limited by applying pitch control or driving the machine to the stall point. Optimum power tracking can be realized by either speed-mode or current-mode control [7].

The implementation of DFIG control and non-linear functions with the Multilevel MATE concept [6] enables an efficient, simultaneous solution of its equations with the system equations. With this

approach we avoid instabilities and inaccuracies in the computation reported when a time step delay in the control system solution is introduced in, for example, EMTPTACS [11].

4. DFIG WIND TURBINE TEST SYSTEM

A doubly fed induction generator wind turbine system from an experimental setup in [7] was modelled and implemented in OVNI. This reference provides the data necessary for modelling of the wind turbine system in phase domain. The DFIG wind turbine system case was extended to include a step-up transformer and a 10 kV double-circuit transmission line connecting the wind turbine to a strong network modelled as an infinite bus. The single-line diagram of the test network is depicted in Figure 3. Inclusion of the connecting network allows us to study the response of the wind turbine to a three-phase fault applied in the middle of Circuit 2 of the transmission line.

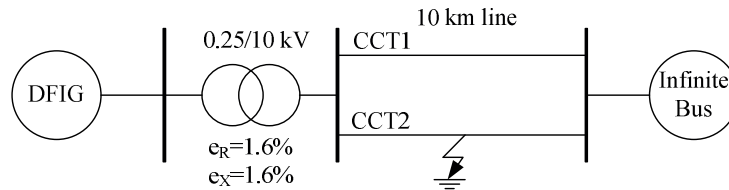

Figure 3. DFIG wind turbine test case

A simulation is first performed for the response of the DFIG wind turbine system to a change in wind velocity following an optimum power tracking system. Initially, the induction machine is operating in steady state with a wind velocity of 9 m/s. The maximum power-tracking system works in current-mode control. At $t = 2$ s, the wind velocity decreases instantaneously to 5 m/s. Reduced wind power, and therefore mechanical torque, cause the DFIG to decelerate, with the deceleration torque being the difference between the turbine's mechanical torque and the torque given by the optimum power curve. Simulation results for mechanical and electrical quantities for the decrease in wind velocity are shown in Figures 4 and 5.

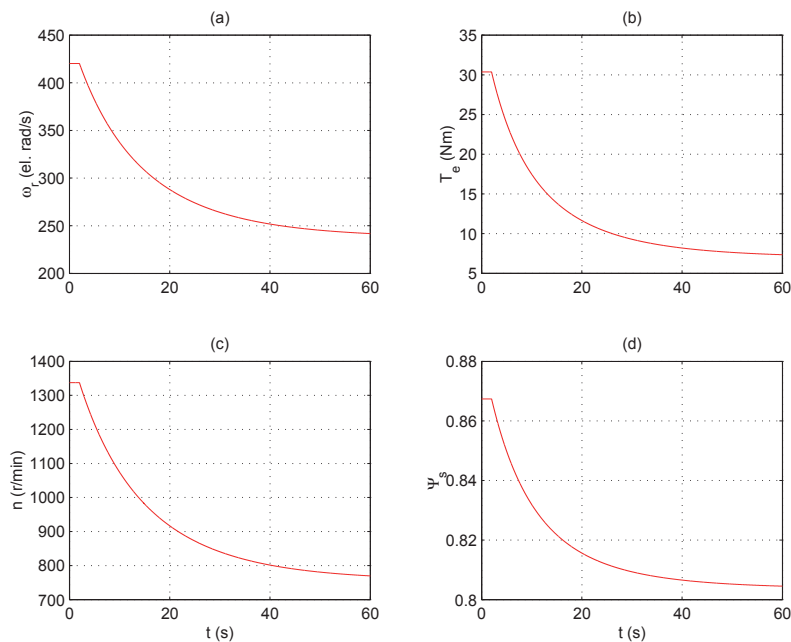

Figure 4. Transient response of the DFIG wind turbine to a step decrease in wind velocity: (a) rotor angular velocity, (b) electromagnetic torque, (c) rotor speed, (d) stator flux

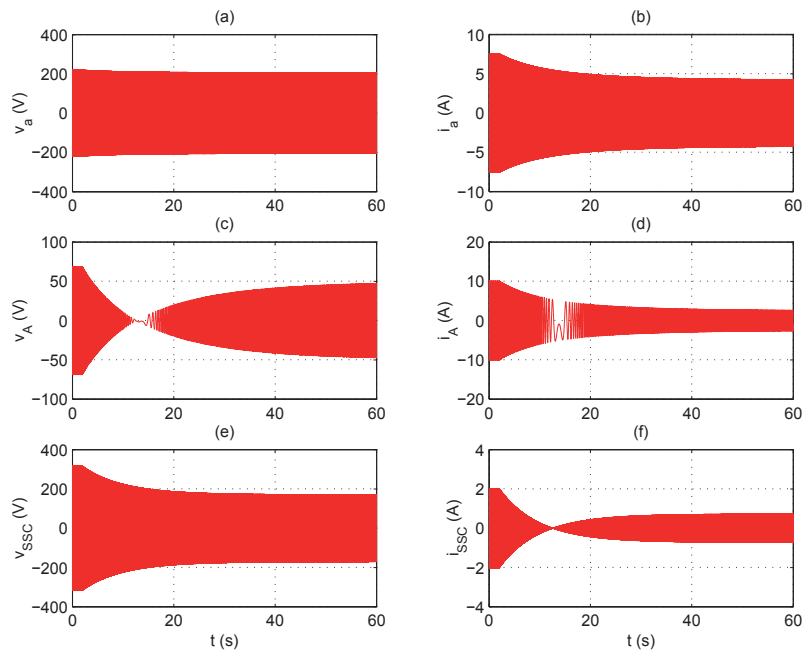

Figure 5. Transient response of the DFIG wind turbine to a step decrease in wind velocity: (a) stator phase to neutral voltage, (b) stator phase current, (c) rotor phase to neutral voltage, (d) rotor phase current, (e) stator-side converter phase voltage, (f) stator-side converter phase current

The second test was done for a three-phase fault at the connecting network. The induction machine operates in steady state with a wind velocity of 8 m/s generating 2700 W of active power that is transmitted to a strong power system modelled as an infinite bus. The DFIG stator-side converter is regulated to maintain its q-axis current at zero, meaning that the reactive power of the induction generator is entirely supplied from the network. At $t = 0.2$ s, a three-phase fault is applied in the middle of circuit CCT2, Figure 3. The fault is removed after 0.1 s without tripping the circuit. The responses of electrical variables of rotor and stator circuits in corresponding dq reference frames are depicted in Figure 6.

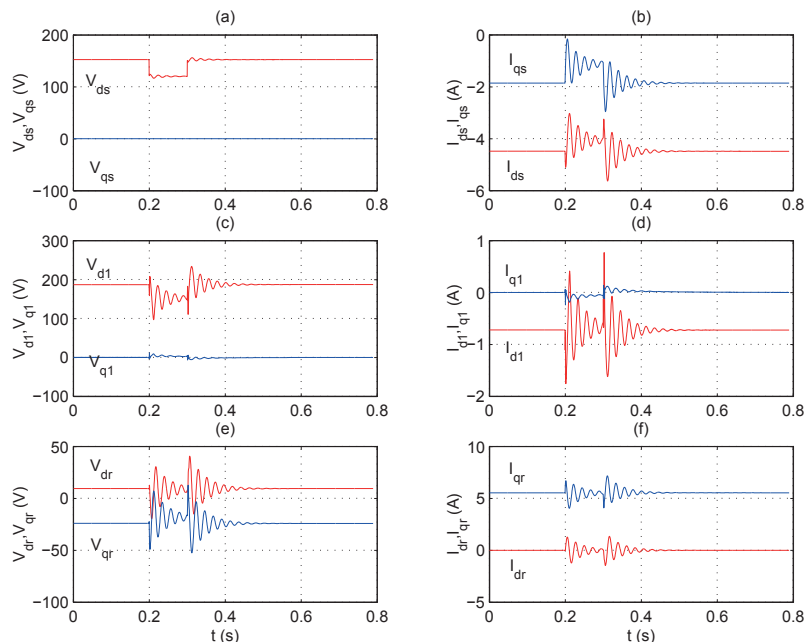

Figure 6. Transient response of the DFIG wind turbine to a three-phase short circuit: (a) stator voltages' dq components, (b) stator currents' dq components, (c) rotor voltages' dq components, (d) rotor currents' dq components, (e) stator-side converter voltages' dq components, (f) stator-side converter currents' dq components

5. CONCLUSION

In this paper we describe a detailed EMTP-type of modelling of a doubly fed induction generator wind turbine system implemented in the OVNI simulator. The test system was taken from an experimental setup described in the literature and replicated with our simulation tool. By using a phase-domain induction machine model we were able to simulate the presented test system with a significantly larger time steps (in the order of the milliseconds) than what is traditionally needed with the dq0 model in the EMTP (in the order of microseconds). Also control and nonlinear equations associated with the test system are solved simultaneously with the machine and network equations. This paper presents a new generation of EMTP-type of tools that is not limited to the analysis of electromagnetic transients. The new, more efficient EMTP models and solution methods are based on the principles of MATE and provide unlimited capabilities for developers and users in implementing a wide range of models and types of power system studies. One of the immediate uses of the new simulation tool can be in developing and testing detailed and approximate models of the new types of alternative power generation such as wind power, as described in this paper.

BIBLIOGRAPHY

- [1] J. R. Martí, L. R. Linares, J. A. Hollman, F. M. Moreira, "OVNI: Integrated Software/Hardware Solution for Real-Time Simulation of Large Power Systems," Conference Proceedings of the 14th Power Systems Computation Conference, PSCC02, Sevilla, Spain, 7 journal pages, June 24th - 28th, 2002.
- [2] J. R. Martí, L. R. Linares, "Real-Time EMTP-based transients simulation," IEEE Transactions on Power Systems, Vol.9, No.3, pp.1309-1317, August 1994.
- [3] S. Acevedo, L. R. Linares, J. R. Martí, Y. Fujimoto, "Efficient HVDC converter model for real time transients simulation," IEEE Transactions on Power Systems, Vol. 14, No. 1, pp. 166-171, February 1999.
- [4] H. W. Dommel, "Digital computer solution of electromagnetic transients in single and multiphase networks," IEEE Transactions on Power Apparatus and Systems, PAS-88(4):388-399, April 1969.
- [5] Gabriel Kron, "Tensorial Analysis of Integrated Transmission Systems, Part III – The Primitive Division," AIEE Transactions, Vol.71, Pt. 3, pp. 814-821, 1952.
- [6] M. Armstrong, J. R. Martí, L. R. Linares, and P. Kundur, "Multilevel MATE for efficient simultaneous solution of control systems and nonlinearities in the OVNI simulator," IEEE Transactions on Power Systems, 21(3):1250-1259, 2006.
- [7] R. Pena, J. C. Clare, and G. M. Asher, "Doubly fed induction generator using back-to-back PWM converters and its application to variable-speed wind-energy generation," IEE Proceedings-Electric Power Applications, 143(3):231-241, May 1996.
- [8] J. R. Martí and T. O. Myers, "Phase-domain induction motor model for power system simulators," In Proceedings of the IEEE Communications, Power, and Computing Conference WESCANEX 95, 1995.
- [9] J. Morren, S.W.H. de Haan, P. Bauer, J.T.G. Pierik, and J. Bozelie, "Comparison of complete and reduced models of a wind turbine with doubly-fed induction generator," In Tenth European conference on power electronics and applications, EPE 2003, Toulouse, France, September 2003.
- [10] F.A. Moreira, J.R. Martí, "Latency techniques for time-domain power system transients simulation," IEEE Transactions on Power Systems, Vol. 20, Issue 1, Feb. 2005 Page(s):246 – 253
- [11] L. Dube and H. W. Dommel, "Simulation of control systems in an electromagnetic transients program with TACS," In Proceedings of IEEE PICA Conference, pages 266-271, 1977.
- [12] Prabha Kundur, Power System Stability and Control, McGraw Hill, 1994.
- [13] Hermann W. Dommel, EMTP Theory Book, 2nd Ed., Microtran Power Systems Analysis Corporation, Vancouver, British Columbia, Canada, pp. 12-3 to 12-9, 1992-1996.
- [14] L. Linares, M. Armstrong, J.R. Martí, "Software Implementation of Controller Representation in the OVNI Simulator," Conference Proceedings of the 15th Power Systems Computation Conference, PSCC05, Liège, Belgium, 6 journal pages, August 22th - 26th, 2005.