

Ana Orešković
Končar - Electrical Engineering Institute
aoreskovic@koncar-institut.hr

Miroslav Poljak
Končar - Electrical Industry Inc.
poljak.dd@koncar.hr

Zdenko Godec
Končar - Electrical Engineering Institute
zgodec@koncar-institut.hr

Rajko Gardijan
Končar - Electrical Engineering Institute
rgard@koncar-institut.hr

ON-SITE ACCURACY COMPARISON OF CAPACITOR AND INDUCTIVE VOLTAGE TRANSFORMERS

SUMMARY

In this paper an on-site accuracy comparison of capacitor and inductive voltage transformers is presented. A 400/110 kV transformer substation in Croatia has been chosen as an appropriate location for the comparison as both types of transformers (capacitor and inductive) operate there simultaneously. Each transformer type is a part of one of the two existing measuring chains for measurement of electrical energy. Their accuracy comparison is, therefore, carried out indirectly, by actually comparing the energies measured by the first and the second measuring chain and then estimating the measurement uncertainty of their difference. Without measurement uncertainty, a parameter that shows the quality of any measurement result, it is generally not possible to conclude about the accuracy of measurement or to compare measurement results mutually. In this measurement uncertainty estimation real on-site conditions in transformer substation, especially those which effect voltage transformer accuracy, have been taken into account (voltage, transformer load, frequency, temperature, etc.)

Key words: Capacitor voltage transformer, inductive voltage transformer, measurement accuracy, measurement uncertainty, measurement of electrical energy

1. INTRODUCTION

Capacitor voltage transformer (hereinafter referred to as CVT) is a special type of voltage transformer. It consists of a capacitor divider and an electromagnetic (inductive) unit. In steady state the error of a CVT depends on operating conditions and changes with voltage, burden, frequency and temperature. Relatively large number of influence quantities that affect the error is an important drawback of this type of transformers. In both the new (from 2012) IEC 61869-5 standard and the old IEC 60044-5 standard (which was official at the time this research was done) for capacitor voltage transformers it is stated that present day service experiences show that CVTs may be satisfactorily used only in the accuracy class 0.5. However, the standards do not list any articles, researches or studies that would support this statement. For inductive voltage transformers there are no such statements and they are generally considered to be sufficiently accurate in service even in higher accuracy classes (like 0,2). These transformers are sensitive to changes in load and burden with some minor influence of temperature on winding resistance variation.

On high voltage revenue metering points (indirect electrical energy measurement) both types of transformers can be found as a part of an electrical energy measuring chain.

A 400/110 kV transformer substation in Croatia is a high voltage revenue metering point and it has two electrical energy measuring chains. In a 400 kV line bay three capacitor (420 kV CVT, accuracy class 0.2), three inductive (420 kV inductive voltage transformers, accuracy class 0,2) and three current transformers (accuracy class 0,2) are installed. Two electrical energy meters of the same type are used. One meter's voltage circuit consists of capacitor and other meter's voltage circuit of inductive voltage transformers. Current circuits (current transformers) are the same for both meters. Measuring chains, therefore, differ only in the type of voltage transformer used.

Simultaneous work of capacitor and inductive voltage transformers in a 400/110 kV substation, shown in figure 1, makes this substation an appropriate location for their on-site accuracy comparison. The conclusion about the accuracy of the transformers is reached indirectly, by comparing the energies (active and reactive) acquired by the meter using capacitor and by the meter using inductive voltage transformers and then estimating the measurement uncertainty of their difference.

The accuracy of measurement is related to and estimated by the uncertainty of measurement. Measurement uncertainty is a parameter, associated with the result of measurement, that characterizes the dispersion of the values that could be reasonably attributed to the measurand [1]. It is an indication of the quality of the result and without measurement uncertainty results cannot be compared, either among themselves or with reference values given in a specification or a standard. Measurement uncertainty has many components that are categorized according to the method used to evaluate them. Generally two types of uncertainty are recognized: type A uncertainty (evaluation of uncertainty by the statistical analysis of series of observations) and type B uncertainty (methods other than the statistical analysis, a priori probability distributions). Measurement uncertainty, like its components, is expressed by standard deviation. Expanded uncertainty is obtained by multiplying the standard uncertainty with a coverage factor k , which is typically in the range 2 to 3. The choice of factor k is based on the chosen probability (approx. 95% for $k=2$ and approx. 99% for $k=3$) that the interval of values covered with expanded uncertainty includes the real value of the measurand [2].

On-site accuracy comparison of capacitor and inductive voltage transformers is done by comparing the energies measured by the two measuring chains these transformers are a part of and by estimating the measurement uncertainty of their difference. Here, one hour values of active and reactive energies over a one year period (from October 2009 to October 2010) have been compared. In order to estimate the uncertainty of a difference, measurement uncertainty of each measuring chain needs to be estimated individually.

2. ESTIMATION OF MEASUREMENT UNCERTAINTY OF ELECTRICAL ENERGY MEASUREMENT

2.1. Mathematical model

Estimation of measurement uncertainty starts with the establishment of a mathematical model of the measurement. A mathematical expression is needed to describe the relationship between the output quantity – the measurand (measurement result) and the input quantities on which the measurand depends. Input quantities can also be observed as results of some other measurement and can themselves depend on other variables [1]. Here, the input quantities are active (W_p) and reactive (W_Q) energy and are given by the following expressions:

$$W_p = (U \cdot I \cdot \cos \phi) \cdot t \quad (1)$$

$$W_Q = (U \cdot I \cdot \sin \phi) \cdot t \quad (2)$$

Input quantities are the voltage (U), current (I), phase angle between voltage and current (ϕ) and time (t).

In the substation there are two electrical energy measuring chains. Chains consist of voltage transformers (capacitor in one and inductive in the other chain), current transformers, electricity meters and secondary lines connecting transformers low voltage terminals to the meter input terminals. Uncertainty of each of the input quantity (U , I , ϕ , t) is linked to one or more of the mentioned measuring chain components.



Figure 1 – Simultaneous work of capacitor and inductive voltage transformers in a 400/110 kV substation

Voltage, current and phase angle are the input signals of the electricity meter. In expressions (1) and (2) they actually define active and reactive power brought to the meter at any time. Uncertainties of voltage, current and phase angle are linked to voltage and current transformers and secondary lines. These are then the sources of uncertainties for active and reactive power as well. Active and reactive energies are read directly from the meter. The meter, therefore, directly contributes to the uncertainty of energy measurement. The uncertainty of time is a part of the overall uncertainty of the meter. The total uncertainty of active and reactive energy consist of the uncertainty of the meter and the uncertainty of the input signal, active or reactive power, brought to the meter.

Generally, if the measurand y is determined from N other, mutually independent, quantities x_1, \dots, x_N through a functional relationship F , than the standard measurement uncertainty $u(y)$ of the measurand y is given, according to [1], by:

$$u(y) = \sqrt{\sum_{i=1}^N \left(\frac{\partial F}{\partial x_i} \right)^2 \cdot u^2(x_i)} \quad (3)$$

where: $u(x_i)$ are standard uncertainties of input quantities from which y is determined.

Measurement uncertainty of active power is according to (3):

$$u(P)_{\%} = \frac{u(P)}{P} \cdot 100\% = \sqrt{u^2(U)_{\%} + u^2(I)_{\%} + (100\% \cdot \tan \phi \cdot u(\phi))^2} \quad (4)$$

Measurement uncertainty of reactive power is according to (3):

$$u(Q)_{\%} = \frac{u(Q)}{Q} \cdot 100\% = \sqrt{u^2(U)_{\%} + u^2(I)_{\%} + \left(100\% \cdot \frac{u(\phi)}{\tan \phi} \right)^2} \quad (5)$$

Expressions (4) and (5) define the uncertainty of active and reactive power per one phase. In a three phase system the total power is the sum of the amount of power in each phase. With the assumption of a symmetrical three phase system (which is in most cases true for high voltage lines) expressions for the uncertainty of total active and reactive power are:

$$u(P_{\text{tot}})_{\%} = \frac{1}{3} \cdot \sqrt{u^2(P_1)_{\%} + u^2(P_2)_{\%} + u^2(P_3)_{\%}} \quad (6)$$

$$u(Q_{\text{tot}})_{\%} = \frac{1}{3} \cdot \sqrt{u^2(Q_1)_{\%} + u^2(Q_2)_{\%} + u^2(Q_3)_{\%}} \quad (7)$$

As already stated, total measurement uncertainty of electrical energy (active or reactive) consists of the uncertainty of electrical power (active or reactive, expressions (6) and (7)) and the uncertainty of the meter:

$$u(W_P)_{\%} = \sqrt{u^2(P_{\text{tot}})_{\%} + u_{\text{mt}}^2(P)_{\%}} \quad (8)$$

$$u(W_Q)_{\%} = \sqrt{u^2(Q_{\text{tot}})_{\%} + u_{\text{mt}}^2(Q)_{\%}} \quad (9)$$

$u_{\text{mt}}(P)_{\%}$ and $u_{\text{mt}}(Q)_{\%}$ are percentage uncertainties of active and reactive energy meter

According to expressions (4) to (9) for the estimation of uncertainty of electrical energy it is necessary to know the uncertainties of voltage $u(U)_{\%}$, current $u(I)_{\%}$, phase angle $u(\varphi)$ and the meter $u_{\text{mt}}(P)_{\%}$ and $u_{\text{mt}}(Q)_{\%}$.

2.2. Measurement uncertainty of voltage

Capacitor and inductive voltage transformers are the sources of uncertainty of voltage measurement. The uncertainty is a consequence of the ratio error which a voltage transformer introduces into the measurement. The actual transformation ratio is not equal to the rated transformation ratio. That is why the voltage brought to the meter multiplied by the rated transformation ratio does not equal the actual voltage on the primary side. Additional error occurs because of the voltage drop on the connection wires in the secondary circuit due to the load current.

IEC standards 61869-5 [3] and 61869-3 [4] for capacitor and inductive voltage transformers define the limits of voltage errors for different accuracy classes under prescribed conditions of use. By using the upper (or lower) error limit $G_{\%}$ according to [3] and [4] and by assuming a symmetric rectangular a priori probability distribution uncertainty of voltage can be calculated as $G_{\%}/\sqrt{3}$. In most cases, however, this leads to overestimation of measurement uncertainty. Actual voltage errors of transformers are smaller than the maximum allowable errors defined in standards. This can be confirmed by inspecting transformers calibration reports. Measurement uncertainty of voltage can be calculated using maximum errors obtained during last calibration $G_{\text{MAX}\%}$ with the uncertainty of calibration $u_{\text{CAL}}(U)_{\%}$ also taken into account [5].

$$u(U)_{\%} = \sqrt{\left(\frac{G_{\text{MAX}\%}}{\sqrt{3}}\right)^2 + \left(u_{\text{CAL}}(U)_{\%}\right)^2} \quad (10)$$

Real working conditions in the substations differ from calibration conditions (transformers were last calibrated in transformers' factory in October 2008 at the temperature of $(20 \pm 5)^{\circ}\text{C}$ and frequency of $(50 \pm 0,1)$ Hz and with burdens of 100% and 0% of rated value). The real maximum error is therefore larger or even smaller than the maximum error from the calibration report. Because of that, additional corrections are required. Real working conditions that affect the error are burden, burden power factor, ambient temperature and frequency (only for CVT). The effect of real working conditions is taken account by using transformers equivalent circuits and the corresponding expressions.

The information about real operating conditions is collected by appropriate measurements. Voltage transformers' real burden, impedance of secondary circuit lines, electrical energy quality parameters and the temperature in the vicinity of the transformers have been measured. The device for measurement of quality of electrical energy registers voltages and currents of all phases, frequency, rapid voltage changes and total harmonic distortion factor of all voltages and currents. For the sake of ambient

temperature measurement two overhead transmission line monitoring devices have been used. The devices have been mounted on a 400 kV high voltage line in two phases, on approx. 1,5 meters distance from the top of CVT insulators. They measure ambient temperature every two minutes.

Results of measurement of the total impedance connected to the secondary transformer terminals show that transformers have low secondary burdens. Such results are to be expected because their secondary circuit devices are electronic devices with high input impedance. Regarding actual burden, capacitor and inductive voltage transformers are treated as transformers operating under no load. Because calibration reports include transformer errors for no load operation (0% of rated burden), error correction because of real burden is not necessary.

The device for energy quality measurement has recorded maximum and minimum frequency in the period from October 2009 to October 2010 and they are 50,1 Hz and 49,9 Hz (deviation of $\pm 0,2\% f_n$).

Maximum and minimum temperature in the period from October 2009 to October 2010 have been recorded by overhead transmission monitoring devices and they are $+40^\circ\text{C}$ (June, July and August 2010) and -16°C (December 2009.g.).

Equivalent circuit of a 420 kV CVT from the substation is shown in figure 2. In calculating the error and error correction, parameters provided by the manufacturer are used. By using these parameters it is not possible to fully reconstruct the measured errors from calibration reports for transformers in the substation. This is because every individual transformer has some extra turns (as a part of a primary winding) for fine tuning of voltage error and these are not taken into account in equivalent circuit. Calculated error from the equivalent circuit approximately matches the one from the calibration report. Using expressions (11) to (14) [6] it is possible to calculate how the error changes with temperature and frequency and what is the maximum possible error (absolute value) regarding the actual substation frequency and temperature range. It is assumed that the errors for the transformers in the substation (real errors from calibration reports) change in the same manner and amount with frequency and temperature as calculated ones. The error correction obtained by using the equivalent circuit is applied on calibration errors and with these corrected errors uncertainty of voltage is calculated using expression (10).

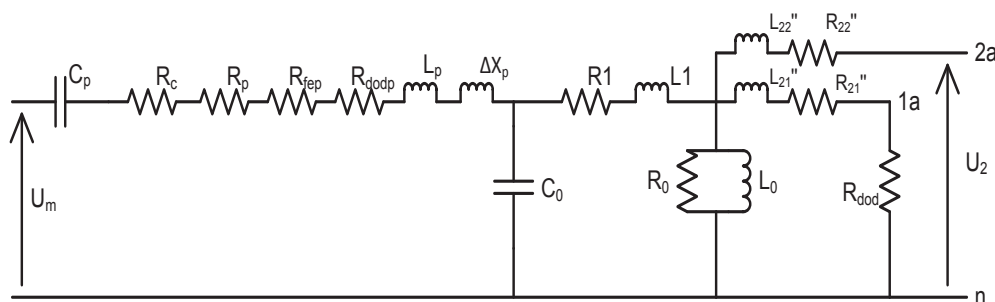

Figure 2 – Equivalent circuit of a 420 kV capacitor voltage transformer

Voltage (ratio) error of a CVT under no load p_0 is calculated using the following expressions:

$$p_0 = \left(-A \cdot \frac{S_{dod}}{U_m^2} + C \right) \cdot 100\% + 0,2\% \quad (11)$$

$$A = 0,8 \cdot (R_c + R_p + R_{fep} + R_{dodp} + R_1 + R_{21}'') + 0,6 \cdot (X_1 + X_{21}'' + X_p + \Delta X_p - X_c) \quad (12)$$

$$C = \frac{X_p + \Delta X_p - X_c}{X_{C0}} - \frac{R_c + R_p + R_{fep} + R_{dodp} + R_1}{R_0} - \frac{X_1 + X_p + \Delta X_p - X_c}{X_0} \quad (13)$$

$$S_{dod} = \frac{U_2^2}{R_{dod}} \quad (14)$$

where U_m is the intermediate voltage of transformer (voltage on intermediate voltage capacitor), U_2 secondary voltage, C_p substitute capacitance of a capacitor divider, R_c substitute resistance of a capacitor divider (resistance due to dielectric loss), R_p substitute resistance of compensating reactor winding, R_{fep} substitute resistance of compensating reactor core, R_{dodp} extra resistance of compensating reactor due to air gap, R_1 primary winding resistance, L_1 primary winding leakage inductance, R_0 and L_0 ohmic and inductive core resistance, C_0 substitute primary winding capacitance, L_{21} , L_{22} , R_{21} , R_{22} first and secondary winding leakage inductance and resistance reduced to the primary side, R_{dod} feroresonant filter resistance and $\Delta X\rho$ extra reactance for error correction.

The change of frequency effects all reactances and the change of temperature has the effect on: C_p , R_c , R_p , R_1 , R_{22} and R_{21} .

Inductive voltage transformers errors do not depend on frequency (for such small frequency deviations) so the errors from calibration reports are corrected only regarding temperature deviation from reference value (20°C). Inductive voltage transformers in the substation are open magnetic core transformers. Temperature effects their voltage error through primary winding resistance R_1 . In the expression for voltage error for this type of transformers according to [7], resistance R_1 appears as a part of a ratio R_1/R_0 , where R_0 is the substitute resistance representing core loss. This ratio is in the order of 10^{-5} and its change has a negligible effect on the error. That is why the errors of inductive voltage transformers are not corrected.

It has already been mentioned that an additional error occurs because of the voltage drop on the connection wires in the secondary circuit. In the substation the impedances of these wires have been measured. The extra error is about 100 times smaller than the errors of voltage transformers and is also considered to be negligible.

2.3. Measurement uncertainty of current

Because of the current transformer ratio error the current of an electricity meter is different than the 400 kV line current multiplied by the rated transformation ratio. The ideal transformation is never achieved so the current transformers represent the source of uncertainty for measurement of current.

The uncertainty of current is determined in the same way as for voltage, using calibration reports (maximum errors $G_{MAX\%}$ measured in the range of 5% to 110% of nominal current) and measurement uncertainty of calibration $u_{CAL}(I)\%$ according to expression (15) [5].

$$u(I)\% = \sqrt{\left(\frac{G_{MAX\%}}{\sqrt{3}}\right)^2 + \left(u_{CAL}(I)\%\right)^2} \quad (15)$$

Current transformers in the substations were calibrated on-site. The errors were measured with real burdens and real burden power factors over a range of primary currents. It is, therefore, not necessary to additionally correct these errors.

2.4. Measurement uncertainty of phase angle

The phase relationship φ between voltage and current in the secondary circuit ($\varphi = \varphi_U - \varphi_I$) is changed compared to their relationship in the primary circuit. This is due to phase angle error of voltage (δ_U) and current transformer (δ_I). The uncertainty of phase angle $u(\varphi)$ equals the uncertainty of the difference of voltage and current transformers phase angle errors $u(\varphi_S) = u(\delta)$, $\delta = \delta_U - \delta_I$ and it is:

$$u(\varphi) = u(\delta) = \sqrt{u^2(\delta_U) + u^2(\delta_I)} \quad (16)$$

By inspecting calibration reports it is possible to make a more realistic uncertainty estimation by calculating with maximum phase angle errors of pair of voltage and current transformers in each phase:

$$\delta_{MAX} = \max\left(|\delta_{VTmin} - \delta_{CTmax}|, |\delta_{VTmax} - \delta_{CTmin}|\right) \quad (17)$$

where: δ_{VTmin} and δ_{VTmax} are the minimum and maximum phase angle errors of voltage transformers from the last calibration report additionally corrected regarding real working conditions. Minimum

and maximum current transformers phase angle errors δ_{CTmin} and δ_{CTmax} from the last calibration report do not need to be additionally corrected (on-site calibration).

Additional correction for phase angle error of CVTs is done in a similar way as for ratio error, using the equivalent circuit from figure 2 and expressions (18) to (20) [6]. All the values in the expressions have been explained in chapter 2.2.

$$\delta_0 = \left(-D \frac{S_{dod}}{U_m^2} + F \right) \cdot 3440 \text{ min} \quad (18)$$

$$D = 0,8 \cdot (X_1 + X_{21}'' + X_p + \Delta X_p - X_c) - 0,6 \cdot (R_c + R_p + R_{fep} + R_{dodp} + R_1 + R_{21}'') \quad (19)$$

$$F = \frac{R_c + R_p + R_{fep} + R_{dodp} + R_1}{X_0} - \frac{X_1 + X_p + \Delta X_p - X_c}{R_0} - \frac{R_c + R_p + R_{fep} + R_{dodp}}{X_{C0}} \quad (20)$$

Phase angle errors of inductive voltage transformers are corrected only regarding ambient temperature deviation from reference value (20°C).

Open core inductive transformer no load phase angle error δ_0 is according to [7]:

$$\delta_0 = 3440 \cdot (R_1 / X_0) [\text{min}] \quad (21)$$

R_1 is primary winding resistance and X_0 reactance representing core losses.

R_1 changes with temperature according to the expression:

$$R_1' = R_{1_{20^\circ\text{C}}} \cdot (1 + k \cdot \Delta T) \quad (22)$$

k is copper temperature coefficient and it's value is 0,00392 [1/K].

At some other temperature than 20°C, δ_0 is:

$$\delta_0' = \delta_0 \cdot (R_1' / R_{1_{20^\circ\text{C}}}) = \delta_0 \cdot (1 + k \cdot \Delta T) \quad (23)$$

Expression (23) is used for inductive voltage transformer phase angle correction.

Finally, measurement uncertainty of phase angle $u(\varphi)$ is calculated as:

$$u(\varphi) = u(\delta) = \sqrt{\frac{(\delta_{MAX})^2}{3} + u_{CALVT}^2(\delta) + u_{CALCT}^2(\delta)} \quad (24)$$

$u_{CALVT}(\delta)$ and $u_{CALCT}(\delta)$ are uncertainties of voltage and current phase angle calibration.

2.5. Measurement uncertainty of active and reactive energy meter

Energy meters in the substation are electronic meters connected to the measuring point via current and voltage transformers. Their nominal current is 1 A and maximum current 1,2 A. They measure active and reactive energy in both energy flow in all quadrants with maximum errors defined by accuracy class 0,2 according to IEC 62053-22 [8] standard for active and accuracy class 2 according to IEC 62053-23 [9] standard for reactive energy. Instead of using maximum errors defined in standards it is possible to estimate meters' uncertainty by combining maximum errors from calibration reports $G_{MAXmt\%}$ (if such reports are available) and the uncertainty of calibration u_{CALmt} . Extra notice should be taken regarding reference conditions defined in standards (reference ambient temperature, voltage, frequency, THD factor, foreign electromagnetic fields, etc.) and the additional percentage error G_{ad} due to deviation of real working conditions from reference ones. In the substation reference conditions have been checked using the data collected by the device for measurement of quality of electrical energy and by performing additional measurements of electrical and magnetic fields in the vicinity of the meters.

The uncertainty of active $u_{mt}(P)$ and reactive energy $u_{mt}(Q)$ meter is:

$$u_{mt\%} = \sqrt{\left(\frac{G_{MAXmt}}{\sqrt{3}}\right)^2 + (u_{CALmt})^2 + \sum_{i=1}^n \left(\frac{G_{adi}}{\sqrt{3}}\right)^2} \quad (25)$$

2.6. Expanded measurement uncertainty of active and reactive energy

The expanded measurement uncertainty of active and reactive energy is obtained by multiplying the expressions (8) and (9) with a coverage factor $k=2$.

$$U(W_p)_{\%} = 2 \cdot \sqrt{u^2(P)_{\%} + u_{mt}^2(P)_{\%}} \quad (26)$$

$$U(W_Q)_{\%} = 2 \cdot \sqrt{u^2(Q)_{\%} + u_{mt}^2(Q)_{\%}} \quad (27)$$

Expanded measurement uncertainties for the measuring chain containing capacitor and the chain containing inductive voltage transformers in the 400/110 kV substation in Croatia for the period from October 2009 to October 2010 are given in table I.

Table I: Expanded measurement uncertainty in a 400/110 kV substation in Croatia for the period from October 2009 to October 2010

	Expanded measurement uncertainty , $k=2$	
	Active energy	Reactive energy
capacitor transformers	0,162 %	3,40 %
inductive transformers	0,159 %	3,41 %

3. ESTIMATION OF MEASUREMENT UNCERTAINTY OF THE DIFFERENCE IN ACTIVE AND REACTIVE ENERGY MEASUREMENT USING CAPACITOR AND INDUCTIVE VOLTAGE TRANSFORMERS

3.1. Mathematical model

Simultaneous measurements of electrical energy with two different measuring chains, one with capacitor and other with inductive voltage transformers, are done in order to establish whether there is a difference between results of the two chains and if that difference is statistically significant.

The average one hour active energy measured with the first chain (CVT transformers) for the period from October 2009 to October 2010 is 200790,6 kWh and with the second chain (inductive voltage transformers) 200535,6 kWh. The average one hour difference in energies measured with the two chains for the same period (8040 pairs of measurement) is 254,69 kWh (0,127%) with a standard deviation of the arithmetic mean of 4,25 kWh.

The average one hour reactive energy measured with the first chain (CVT transformers) for the period from October 2009 to October 2010 is -48288,1 kvarh and with the second chain (inductive voltage transformers) -48336,1 kvarh. The average one hour difference in energies measured with the two chains for the same period (8040 pairs of measurement) is 48 kvarh (0,099%) with a standard deviation of the arithmetic mean of 4,31 kvarh.

Energies measured with the two chains are not mutually independent. Current transformers in all phases are shared by both chains. All three currents and all three current phase angles are variables on which both energies depend. The energies are, therefore, correlated and this correlation needs to be taken into account while defining the mathematical model for the uncertainty of their difference.

Generally, if the measurand y is determined from N other input correlated quantities x_1, \dots, x_N through a functional relationship F , then the measurement uncertainty of y is given by [1]:

$$u(y) = \sqrt{\sum_{i=1}^N \left(\frac{\partial f}{\partial x_i} \right)^2 u^2(x_i) + 2 \cdot \sum_{i=1}^{N-1} \sum_{j=i+1}^N \frac{\partial f}{\partial x_i} \frac{\partial f}{\partial x_j} u(x_i, x_j)} \quad (28)$$

$u(x_i, x_j)$ are covariances associated with x_i and x_j

If two input quantities x_1 and x_2 depend on a set of uncorrelated variables q_1, q_2, \dots, q_L so that $x_1 = F(q_1, q_2, \dots, q_L)$ i $x_2 = G(q_1, q_2, \dots, q_L)$, although some of these variables may actually appear only in one function and not the other, than the covariance associated with x_1 and x_2 is:

$$u(x_1, x_2) = \sum_{i=1}^L \frac{\partial F}{\partial q_i} \frac{\partial G}{\partial q_i} u^2(q_i) \quad (29)$$

Measurement uncertainty of difference in measured active energy using capacitor (CVT) and inductive (IVT) transformers $W_{PD} = W_{PCVT} - W_{PIVT}$ is calculated according to (28) and (29):

$$\begin{aligned} u^2(W_{PD}) = & \left(\frac{u(W_{PCVT})_{\%}}{100\%} \cdot W_{PCVT} \right)^2 + \left(\frac{u(W_{PIVT})_{\%}}{100\%} \cdot W_{PIVT} \right)^2 + u^2(\overline{W_{PD}}) - \\ & 2 \cdot \left(\frac{u(W_{PCVT1}, W_{PIVT1})_{\%}}{100\%} \cdot W_{PCVT1} \cdot W_{PIVT1} + \frac{u(W_{PCVT2}, W_{PIVT2})_{\%}}{100\%} \cdot W_{PCVT2} \cdot W_{PIVT2} \right. \\ & \left. + \frac{u(W_{PCVT3}, W_{PIVT3})_{\%}}{100\%} \cdot W_{PCVT3} \cdot W_{PIVT3} \right) \end{aligned} \quad (30)$$

where:

$$\begin{aligned} u(W_{PCVTi}, W_{PIVTi})_{\%} &= \frac{u(W_{PCVTi}, W_{PIVTi})}{W_{PCVTi} \cdot W_{PIVTi}} \cdot 100\% \\ &= \frac{u^2(I_i)_{\%}}{100\%} + \tan(\phi_{CVTi} - \phi_{li}) \cdot \tan(\phi_{IVTi} - \phi_{li}) \cdot u^2(\phi_{li}) \cdot 100\% \end{aligned} \quad (31)$$

$i = 1, 2, 3$

Measurement uncertainty of difference in measured reactive energy using capacitor (CVT) and inductive (IVT) transformers $W_{QD} = W_{QCVT} - W_{QIVT}$ is calculated according to (28) and (29):

$$\begin{aligned} u^2(W_{QD}) = & \left(\frac{u(W_{QCVT})_{\%}}{100\%} \cdot W_{QCVT} \right)^2 + \left(\frac{u(W_{QIVT})_{\%}}{100\%} \cdot W_{QIVT} \right)^2 + u^2(\overline{W_{QD}}) - \\ & 2 \cdot \left(\frac{u(W_{QCVT1}, W_{QIVT1})_{\%}}{100\%} \cdot W_{QCVT1} \cdot W_{QIVT1} + \frac{u(W_{QCVT2}, W_{QIVT2})_{\%}}{100\%} \cdot W_{QCVT2} \cdot W_{QIVT2} \right. \\ & \left. + \frac{u(W_{QCVT3}, W_{QIVT3})_{\%}}{100\%} \cdot W_{QCVT3} \cdot W_{QIVT3} \right) \end{aligned} \quad (32)$$

where:

$$u(W_{QCVTi}, W_{QIVTi})_{\%} = \frac{u(W_{QCVTi}, W_{QIVTi})}{W_{QCVTi} \cdot W_{QIVTi}} \cdot 100\% \\ = \frac{u^2(I_i)_{\%}}{100\%} + ctg(\phi_{CVTi} - \phi_i) \cdot ctg(\phi_{IVTi} - \phi_i) \cdot u^2(\phi_i) \cdot 100\% \quad (33)$$

$$i = 1, 2, 3$$

$u(\overline{W_{PD}})$ and $u(\overline{W_{QD}})$, are A types of uncertainty, statistically estimated standard deviations of arithmetic means of series of observed differences in measured energies. Tangents and cotangents of phase angles per phases are average values for the period from October 2009 to October 2010.

3.2. Standard measurement uncertainty of the difference in active and reactive energy measurement when using capacitor and inductive voltage transformers

Standard measurement uncertainty of the difference in active and reactive energy measurement when using capacitor and inductive voltage transformers according to expressions from (30) to (33) is given in table II.

Table II: Standard measurement uncertainty of the difference in active and reactive energy measurement using capacitor and inductive transformers for the period from October 2009 to October 2010

	Standard measurement uncertainty of difference
Active energy $u(W_{PD})$	192 kWh
Reactive energy $u(W_{QD})$	1153 kvarh

3.3. Statistical difference test

In statistics, a result is called statistically significant if it is unlikely to have occurred by chance. Statistical significance of the determined average differences in active (254,69 kWh) and reactive (48 kvarh) energies measured is concluded on by conducting a statistical test of difference, by stating and then checking the hypothesis (so called null hypothesis) about the differences.

For the null hypothesis a claim is chosen that there is no difference between the energies measured using capacitor and inductive transformers, that the difference is zero. In the process of testing, a probability of rejecting the true hypothesis is defined in advance. This is actually the probability of test error and it is called the significance level – α . The value of α is in most cases 0,05 or 5%. In order to check null hypothesis, a so called z value is calculated as:

$$z = \Delta W / u(\Delta W) \quad (34)$$

where: ΔW is the average difference of the measured energies (active and reactive) and $u(\Delta W)$ measurement uncertainty of that difference ($u(\Delta W) = u(W_{PD})$ for active and $u(\Delta W) = u(W_{QD})$ for reactive energy according to table II). Null hypothesis is accepted in the case $|z|$ is smaller than the critical z value (z_{cr}), that is if ΔW lies inside the interval $0 \pm z_{cr} \cdot u(\Delta W)$ (95% confidence interval if $\alpha=0,05$). Assuming a normal distribution, z_{cr} is 1,96.

In a 400/110 kV substation in Croatia z value for active energy, according to (34), is 1,33 and for reactive energy 0,04 (absolute values) and in both cases is less than the critical value. Null hypothesis is accepted for both the differences, in active and reactive energy. The differences in energies measured using capacitor and inductive transformers are not statistically significant at 95% level of confidence.

4. CONCLUSION

Measurement of electrical energy with the help of capacitor voltage transformers in the 400/110 kV substation in Croatia is just as accurate as electrical energy measurement with the help of inductive voltage transformers. The same accuracy is achieved under operating conditions that include the operation of voltage transformers with low burden (no load operation), frequency deviation range of $\pm 0,2\% f_n$, voltage variation range of $\pm 10\% U_n$ and ambient temperature change from -16°C to $+40^\circ\text{C}$ in a period of one year. The expanded measurement uncertainty ($k=2$) of active energy measurement is in both cases 0,16% in relation to the measured active energy. Measurement uncertainties are the same for reactive energy measurement as well (3,4% in both cases).

By comparing measurements of energies over a period of one year (October 2009 to October 2010) very small differences between the measurement with the help of the capacitor and with the help of the inductive voltage transformer have been determined (0,127% or 255 kWh and 0,099% or 48 kvarh). The differences are neither statistically nor technically significant. Differences occur at random and cannot be associated with different types of voltage transformers used in electrical energy measuring chains.

Type of capacitor voltage transformer investigated in this article, can be, providing the same or similar operating conditions as indicated, satisfactorily used as a voltage measuring instrument of accuracy class 0,2 in the measuring chain for electrical energy measurement.

REFERENCES

- [1] Guide to the expression of uncertainty in measurement, ISO, 1993., ISBN 92-67-10188-9, International Organization of standardization, 1993.
- [2] Z. Godec: Expressing the result of measurement (in Croatian), Graphis Zagreb, 1995
- [3] IEC 61869-5: 2012, Instrument transformers – Part 5: Specific requirements for capacitor voltage transformers
- [4] IEC 61869-3: 2012, Instrument transformers – Part 3: Specific requirements for inductive voltage transformers
- [5] Z.Godec, S.Gazivoda, J.Šimić, M. Lasić, N.Knez: Experimental research, localization of some non technical electrical energy losses and establishing their causes in specific points in distribution network, Annex P6: Measurement uncertainty of electrical energy. Ordered by: HEP d.d., Development sector, 2006 (in Croatian)
- [6] I.Paić: Software for voltage and phase error calculation of capacitor voltage transformer, thesis, FER, Zagreb, 2003.g. (in Croatian)
- [7] V.Bego: Instrument transformers, Školska knjiga, Zagreb, 1977 (in Croatian)
- [8] IEC 62053-22, Electricity metering equipment (a.c.) – Particular requirements, Static meters for active energy (classes 0,2S and 0,5S)
- [9] IEC 62053-23:2003, Electricity metering equipment (a.c.) – Particular requirements, Static meters for reactive energy (classes 2 and 3)