

Bruno Jurišić
EDF R&D, France
bruno.jurismic@edf.fr

Alain Xemard
EDF R&D, France
alain.xemard@edf.fr

Philippe Guuinic
EDF R&D, France
philippe.guuinic@edf.fr

Ivo Uglešić
University of Zagreb, Croatia
ivo.uglesic@fer.hr

Françoise Paladian
Université Blaise Pascal, France
francoise.paladian@lasmea.univ-bpclermont.fr

CASE STUDY ON TRANSFORMER MODELS FOR CALCULATION OF HIGH FREQUENCY TRANSMITTED OVERVOLTAGES

SUMMARY

Events such as lightning, switching of vacuum circuit breaker or switching operations in gas insulated substation (GIS) generate high frequency overvoltages. An equipment in a transmission or a distribution system has to be protected against such phenomena.

Unfortunately, the traditional transformer models available in Electromagnetic transient simulations program (EMTP-like) software packages are not capable of representing transformer behavior in a transient state, which includes high frequencies. Moreover, high frequency transformer models are often too complex or require confidential information on transformer geometry. However, in the design stage of insulation coordination it is particularly important to accurately calculate transmitted overvoltages through transformers.

In the scope of this paper two different transformer models for high frequency, are developed in an EMTP-type software program. The first model named “Black box” derives solely from the values measured on the transformer terminals and does not require any knowledge of the transformer inner geometry. The second model named “Grey box”, is based on a lumped RLC parameters network, whose values are derived from the simple geometry of the transformer window and from the nameplate data. Furthermore, the models’ capabilities to characterize a transformer at high frequencies are analyzed. The case study is done on a distribution transformer which is to be located inside a power plant. The transmitted overvoltages calculated with the models in the EMTP-type software program are compared with measurements.

Key words: “Black box”, EMTP-type software, “Grey box”, high frequency transients, lightning, rational approximation, transformer modelling

1. INTRODUCTION

Surges, which occur in a power system, are often caused by events such as lightning. Besides the risk of failure on the high voltage side of the transformer, surges can be transmitted through the transformer and can cause failure either of the transformer itself or the components, which are located after the transformer (i.e. for instance distribution network in a power plant). Therefore, the protection of the equipment in the power system against such phenomena should be carefully investigated.

In the design stage of insulation coordination, which is usually based on electromagnetic transient simulations, transmitted overvoltages through transformers should be accurately calculated in order to have an adequate protection of the system components. Since those overvoltages include high frequency components, the traditional, low frequency transformer models cannot be used for accurate calculation of overvoltages. Therefore, it is particularly important to have a proper transformer model, accurate also for representing the high frequency transformer behavior [1].

Two different transformer models, which are able to represent transformer high frequency behavior, are developed in the EMTP-RV software program [2]. The models are derived from the information, which are usually provided to the transformer buyer's company, since the detailed inner geometry of the transformer is the property of the transformer manufacturer.

The first model named "Black box", is derived solely from the values measured on the transformer terminals and does not require any knowledge on the transformer inner geometry. The voltage ratio between the transformer's terminals voltages is measured using a frequency response analyzer; this equipment is usually used for FRA measurement [3], [4]. This approach includes the transformer's admittance matrix calculation from the measurement results, the approximation of its elements by using rational approximation, and a state space block representation in EMTP-RV software program [5], [6]. The transformer admittance matrix's elements can also be derived from scattering parameters measurement [7].

The second model is a "Grey box", based on a lumped RLC parameters network, whose values are derived from the simple geometry of the transformer window. Model parameters are calculated using analytical expressions and finite element calculation method (FEMM software program) [8]-[11].

In this paper, we propose to analyze the capabilities of a "Black box" model and a "Grey box" model to characterize a transformer at high frequencies. The case study is done on a distribution transformer which is to be located inside the power plant. Both models presented in this paper are used to represent the same transformer. The overvoltages calculated with the models in the EMTP-RV software program are compared with measurements. The comparison is done for several connections of transformer terminals in order to validate the models.

2. "BLACK BOX" MODEL PRINCIPLE

In this section, a basic approach for deriving the "Black box" model based on state space equations from measurement results is described. More precisely, a procedure for measuring the admittance (Y) matrix elements of a transformer with FRA equipment and building from these measurements a model compatible with EMTP-RV is presented.

2.1. Measurements of admittance matrix elements

The frequency response analyzer, which is used for the measurement, is only capable of measuring the ratio (H) between the input (V_{in}) and the output (V_{out}) voltages.

$$H(f) = \frac{V_{out}(f)}{V_{in}(f)} \quad (1)$$

Since the FRA measurement equipment is not normally used for measuring Y matrix, a procedure for measuring this matrix is established. This measurement procedure stems from the following expression:

$$\begin{pmatrix} I_1 \\ I_2 \\ \vdots \\ I_{N-1} \\ I_N \end{pmatrix} = \begin{pmatrix} Y_{1,1} & \cdots & Y_{1,N} \\ \vdots & \ddots & \vdots \\ Y_{N,1} & \cdots & Y_{N,N} \end{pmatrix} \begin{pmatrix} V_1 \\ V_2 \\ \vdots \\ V_{N-1} \\ V_N \end{pmatrix} \quad (2)$$

Expression (2) is valid for the transformer with N terminals. However, the transformer considered in this paper has 11 terminals: 3 terminals of HV winding (A, B, C), neutral of HV winding (N), 6 terminals of two secondary LV windings (a1, b1, c1, a2, b2, c2) and a tank (optional).

2.1.1. Off-diagonal elements

The electric circuit, which represents the frequency network analyzer connection for measuring off-diagonal Y matrix elements, is given in the figure 1. The coaxial cables are shown in blue and the flat braids are shown in red.

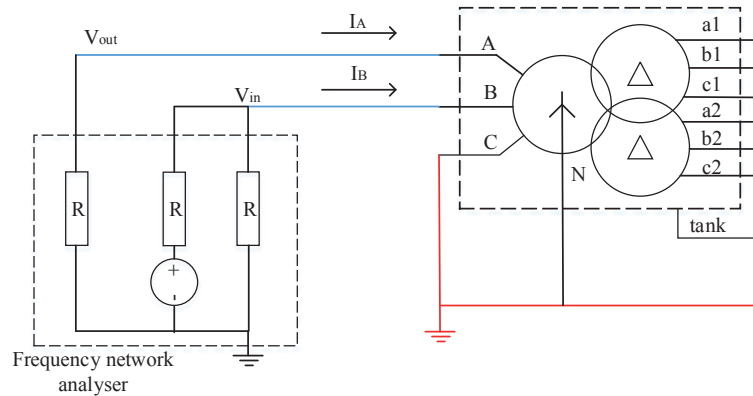

Figure 1 - Electric scheme for measuring off-diagonal Y matrix

In the equipment, which was used, the source and the reference leads use the same coaxial cable, as it is shown in the figure 1. The matching resistances (R) of frequency network analyzer terminals (source, reference and response) should be the same value as the characteristic resistance of the coaxial cables in order to avoid wave reflections (which can have some effect on the measurement results) at the connection between the network analyzer and the coaxial cables. Therefore, in our calculations we are neglecting the resistance of the coaxial cables. Furthermore, the influences of the connections which are made by straight braids are also neglected.

Note that the measurements of the reference and the response signals are made across the matching resistance of the equipment.

In the figure 1, the measurement configuration for measuring the $Y_{1,2}$ element of the admittance matrix is shown. Since all the terminals which are not under measurement are grounded, their voltages are equal to 0 V (if the effect of the flat braids is neglected). Therefore, from the equation (2), for the connection from the figure 1, the following general expression for calculating the matrix off-diagonal elements can be deduced:

$$Y_{i,j}(f) = -\frac{V_i(f)}{V_j(f)} * \left(Y_{i,i}(f) + \frac{1}{R} \right) \quad (3)$$

2.1.1. Diagonal elements

For measuring the diagonal elements of the admittance matrix, the matching resistance of the response lead is used as a shunt in order to connect the value of the current flowing through the response lead with its voltage (V_{out}). Therefore, there was no need to use an additional shunt for the measurements.

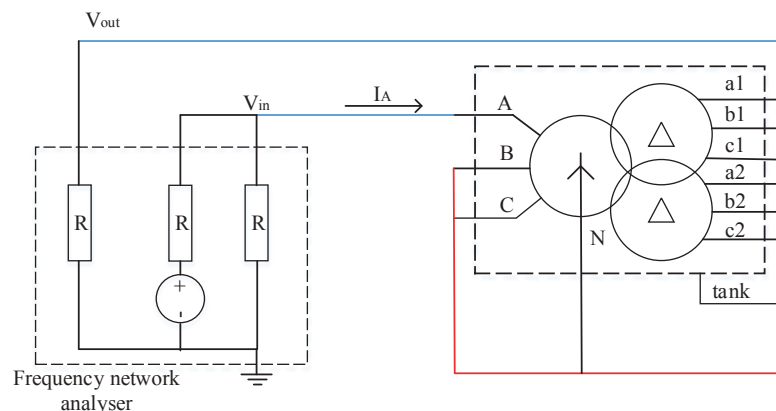

Figure 2 - Electric scheme for measuring diagonal Y matrix

Based on the connection of the figure 2, a general expression for calculating the matrix diagonal elements can be deduced:

$$Y_{i,i}(f) = \frac{I_i(f)}{(V_{in}(f) - V_{out}(f))} = \frac{V_{out}(f)}{R * (V_i(f) - V_{out}(f))} \quad (4)$$

Note that the procedure described in this section of the document is valid for a N terminal admittance matrices.

2.2. Measurements results

The measurements are done on a 64 MVA, 24/6,8/6,8 kV, YNd11d11 transformer. The matching resistance of the frequency network analyzer is 50 Ω and the accuracy better than ± 1 dB in the measurement range 0-75 dB. The frequency range of the apparatus is 20 Hz-2 MHz. The measurements are done with the tank grounded (as it is on site). Therefore, we can model the transformer as a 10 terminal system. This simplification reduces the number of measurements needed to make a model (in this case from 121 to 100), which is equivalent of almost 2 hours if we consider that the time spent per measurement for one element is approximately 5 minutes.

Measured admittance matrix elements versus frequency are shown in the figure 3. Expressions used to calculate the admittance matrix from the measurements were already given in the text (expression (3) and (4)).

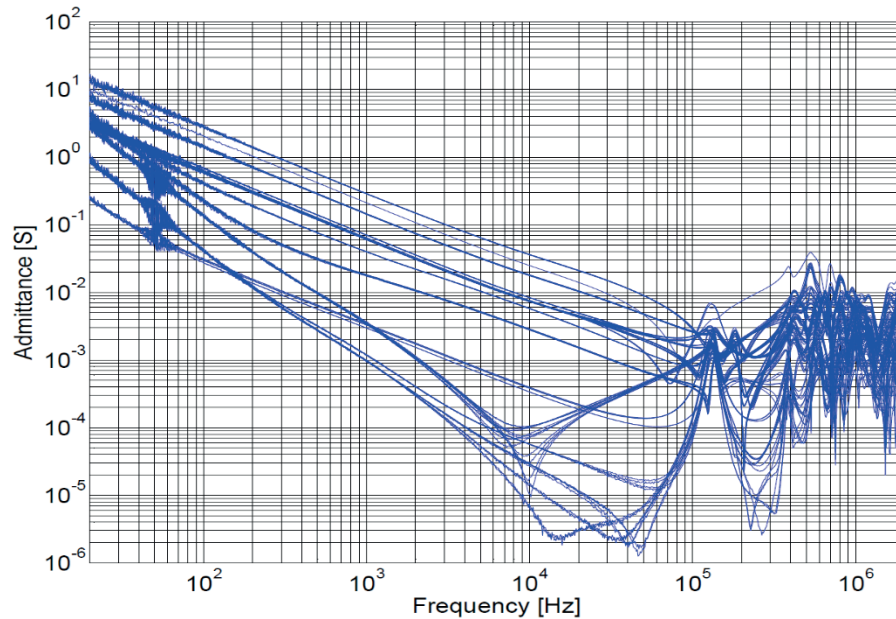

Figure 3 - $Y(f)$ amplitude for transformer with the tank grounded

Each curve shown in the figure 3 consists of the 1040 frequency points over the full frequency range of the equipment (from 20 Hz to 2 MHz). The calculated values are in accordance with the values of the measured voltage ratios, H and similar to the ones obtained in recent similar studies [7].

Noise which occurs around 50 Hz, from the figure 3, is probably caused by interferences with the power frequency of a power supply of the measurement equipment. Noise which occurs when the measurements amplitude is low is probably caused by the lack of accuracy of the measurement equipment outside its rated measurement area (0-75 dB).

2.3. Inclusion of the measurements data in EMTP-type software

Since the transformer model has to be built in an EMTP-type software program, the results of the measurement have to be prepared for the input in the computer software. This can be done by using the fitting method to approximate each admittance matrix element $Y_{ij}(f)$ with a rational expression [12]-[16] of the type given below:

$$Y_{ij}(s) \approx \sum_{n=1}^N \frac{c_{n,ij}}{s - a_{n,ij}} + d_{ij} + s * e_{ij} \quad (5)$$

In the equation (5) $a_{n,ij}$ represents the poles which can be either real or complex conjugated pair, $c_{n,ij}$ represents the residues which can also be either real or complex conjugated pair, d_{ij} and e_{ij} are the real values constant. s stands for $j2\pi f$ where f is frequency. N is number of poles used for approximating each matrix element.

These rational functions have to be both stable and passive since the transformer is a passive component of the electric grid. Stability is obtained by keeping only the poles which are stable. Passivity is enforced by perturbation of the residues and constants values in order to match the passivity criterion [17]-[20]:

$$P = \text{Re}\{v^* Y_{i,\text{fit}} v\} > 0 \quad (6)$$

Rational expression (5) allows using state space equations as shown below:

$$sX(s) = A * X(s) + B * U(s) \quad (7)$$

$$I(s) = C * X(s) + D * U(s) + sE * U(s) \quad (8)$$

Matrices A, B, C, D and E for state space representation can be input directly into the state space block in EMTP-RV. These matrices are obtained by using the values of poles and residues from rational functions (5) and forming the function given below:

$$I(s) = Y(s) * U(s) = \left[\frac{C * B}{(s[I] - A)} + D + sE \right] * U(s) \quad (9)$$

Expression (9), in which [I] is the identity matrix, can be obtained from equations (7) and (8). It represents the relation between the terminal currents and voltages of the transformer, suitable to represent the rational function given by expression (5).

If some of the matrices elements are complex (as they usually are, since some poles and residues can be complex), a transformation to real values should be done [21]. This transformation does not have any effect on the accuracy of the model. State space representation is used to describe a linear network. Therefore, it can be used to represent a transformer, since transformer behavior is linear at high frequencies. The advantage of using these equations is the straightforward conversion from the frequency (measurements) to the time domain (EMTP-type software), without changing the values of the A, B, C, D and E matrices.

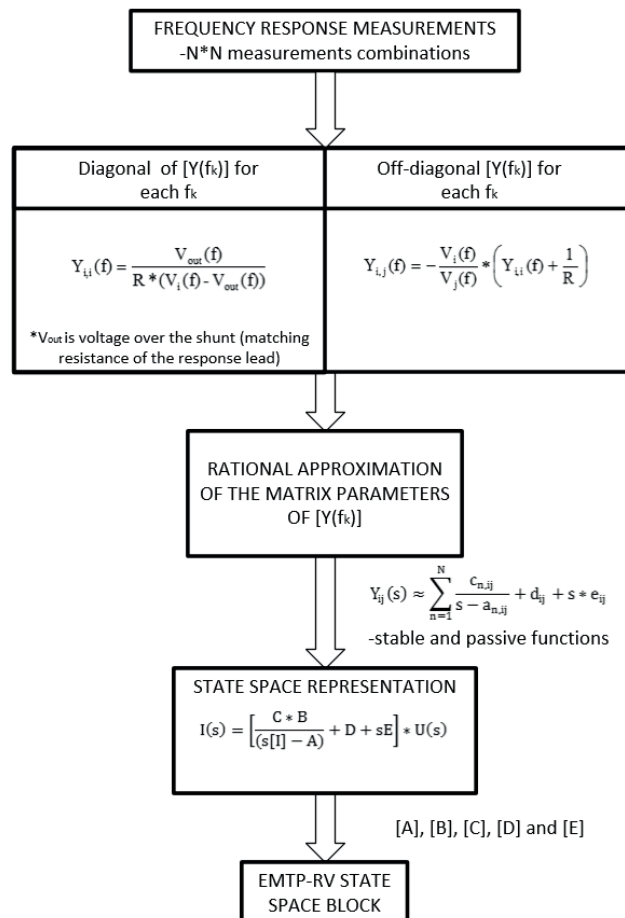

Figure 4 - Procedure for deriving the "Black box" transformer model in EMTP-RV.

The complete procedure for building the "Black box" transformer model in EMTP-RV, from the frequency response measurement is shown in the figure 4. Note that the given procedure is directly applicable for transformers with N terminals.

2.4. EMTP-RV model

As it was already indicated, the model of the transformer in EMTP-RV uses inbuilt state space block, from the standard library. The 10 terminal model of 64 MVA, distribution transformer unit, developed in EMTP-RV, is shown in the figure 5.

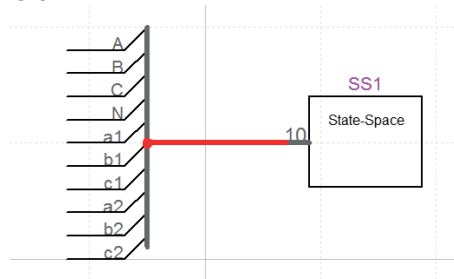

Figure 5 -10 terminal transformer model in EMTP-RV

3. THE “GREY BOX” MODEL: PRINCIPLE

A simple “Grey box” transformer model, derived from the basic geometry of the transformer window, and suitable for the calculation of transmitted overvoltages through transformer was developed.

In this section the idea of the “Grey box” RLC models is first presented. Then, the method for deriving the RLC parameters from the geometry of the transformer window is described. Model parameters are derived from the data provided by the transformer manufacturer, using analytical expressions and a finite element calculation method (FEMM software program). Furthermore, the model implementation in EMTP-RV is presented.

The model which is explained further in this paper can be called “Grey box” model, since the information required to build such a model is basic and freely accessible to the power utility. It is based on lumped RLC equivalent network [8]-[10]. Its elements values can be derived from the geometry of the transformer window and from capacitances inside the transformer, whose measurements can be requested during the transformer production process. Each RLC element represents a physical part of the transformer. The example of a RLC network which represents one phase of a two winding transformer is given below:

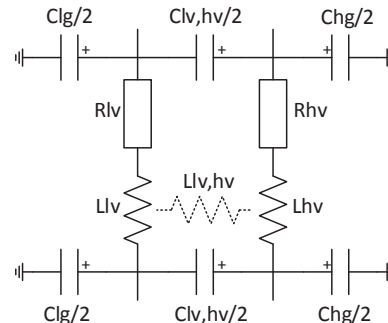

Figure 6 - RLC network for one phase of a two winding transformer

From the figure 6, it can be seen that the transformer is represented with the inductances and resistances of the windings itself, the mutual inductance, capacitance between the windings and capacitances to the ground of each winding.

3.1. Parameters calculation

3.1.1. Resistances

The values of the resistance parameters for the RLC model are usually derived from nameplate data which includes the transformer configuration and the windings resistances. Note that the variation of resistance with frequency due to the skin effect is not included.

3.1.2. Inductances

The inductances values are calculated using the magnetostatic solver in FEMM. For magnetostatic model, FEMM solver calculates magnetic potential (A) distribution from which magnetic field intensity (H) and flux density (B) can be deduced. To define a magnetostatic problem, the following input parameters should be given: complex material relative permeability in each axes direction (it can be linear or nonlinear); source current density for each material; type of lamination of the material; boundary conditions; current flowing through the windings and number of turns.

After all the parameters are set, the calculation of inductance in FEMM can be done in two different ways: by calculating the integrals of magnetic potential (A) over the windings area or from the stored magnetic energy. Since the calculation of inductance from the magnetic energy stored in the system is very time consuming due to the calculation of the integrals over the whole geometry of the model for each inductance, in this paper only the calculation of inductances from the magnetic potential is presented.

In order to represent self inductances as a function of magnetic potential, the following expression is introduced [22]:

$$L_{ii} = \frac{\int_{V_i} J_i A_i dV}{I_i^2} \quad (10)$$

, where A_i is a magnetic potential caused by the i -th winding, I_i is a current flowing through the i -th windings. J_i is the density of the current in i -th winding while V_i is the volume of the same winding.

The integral in the numerator of the expression (10) can be calculated in FEMM as an integral $A \cdot J$ over the area of winding in which current I_i is flowing while currents in all the other windings is set to 0 A.

In order to represent mutual inductances as a function of magnetic potential, the following expression is introduced:

$$L_{ij} = \frac{\int_{V_j} J_j A_i dV}{I_i I_j} = \frac{\int_{V_i} J_i A_j dV}{I_i I_j} \quad (11)$$

The integral of the numerator of the expression (11) can be rewritten into a simpler form, since $n_j = J_j \cdot a_j$, where a_j is a cross section surface of j -th winding [22]:

$$L_{ij} = \frac{\int_{V_j} J_j A_i dV}{I_i I_j} = \frac{\int_{V_j} \frac{n_j I_j}{a_j} A_i dV}{I_i I_j} = \frac{n_j \int_{V_j} A_i dV}{a_j I_i} \quad (12)$$

The integral from the equation (12) can be calculated in FEMM as an integral A (FEMM can calculate directly A/a_j) over the area of j -th winding while the current I_i is flowing through the i -th winding and generates the magnetic potential (A_i) in the system. Note that all the other currents should be set to 0 A [22].

3.1.3. Capacitances

The capacitances values can be calculated from the analytical expression or using the electrostatic solver in FEMM.

For the electrostatic model, FEMM solver calculates potential (V) distribution from which electric field intensity (E) and electrical charge density (D) can be determined. To define a problem, the following input parameters should be given: material relative electrical permittivity in each axes direction; charge density for each material; boundary conditions for each material region (fixed voltage is used); prescribed voltage or total charge in the conductor.

The capacitances are calculated in two different ways: by using the analytical expression or by using the FEMM software (from the electrostatic energy or from the charge) [22]. In this document only the capacitance calculation by using the analytical expression is presented.

Since the windings are concentrically wound around the leg of the core, the analytical expression for capacitance of cylindrical capacitors can be used for calculating the capacitance [8]:

$$C = 2\pi\epsilon_0\epsilon_r \frac{l+d}{\ln\left(\frac{R_1}{R_2}\right)} \quad (13)$$

In the expression (13), l is the height of the winding, R_1 is the outer diameter of the inner winding, R_2 is the inner diameter of outer winding and d is distance between the windings. ϵ_r from the expression (13) represents the relative permittivity of the transformer oil. Since the real value of this parameter is not known, it is assumed that it is equal to 2,2 [10]. The same value for ϵ_r is used in the calculations in FEMM.

In the numerator of the expression (13), d is added to l in order to compensate for the fringing of the fields at the ends of the cylinders [8].

3.2. EMTP-RV model

In this section the model implementation in EMTP-RV is explained and a short procedure for deriving the “Grey box” model is given. In the figure 7, below, a comparison between the electric scheme of 1-phase of the transformer model and its implementation in EMTP-RV is made.

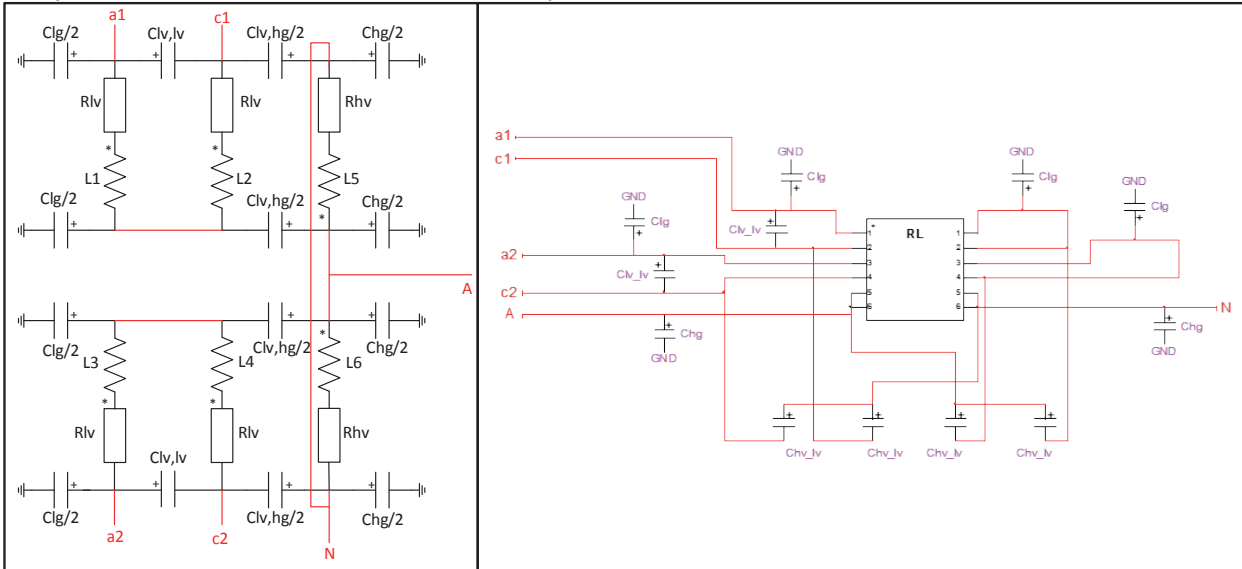

Figure 7 - The electric scheme of a 1-phase of the transformer model (left) and its implementation in EMTP-RV (right)

Note that in the electric scheme of the figure 7, the mutual inductances are not shown. Nevertheless, they exist between each part of the windings. It can also be seen that the inductance matrix together with the self-resistances of the parts of the windings are implemented in EMTP-RV with RL block. The capacitances are given in addition, outside the block.

3-phase transformer model is constructed from three 1-phase transformer models. 1-phase transformer models are connected together in YNd11d11 connection.

Besides the connections between phases, the transformation from 1-phase model to 3-phase model is straightforward if the interphases mutual inductances and capacitances are neglected, as they are in the model that has been developed. The differences between the phase inductances and capacitances, which depend on the location of each phase winding inside the transformer tank, are also neglected in the model.

The complete procedure for building the “Grey box” transformer model in EMTP-RV, from the nameplate and the simplified transformer window geometry data is shown in the figure 8.

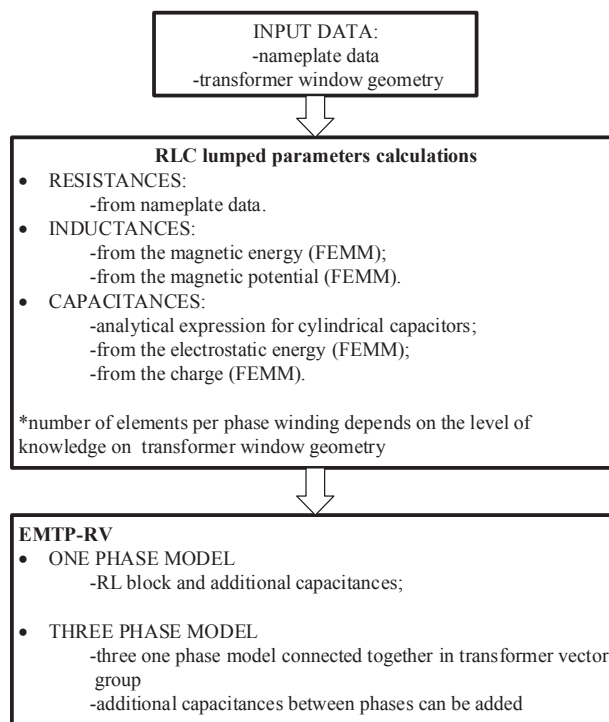

Figure 8 - Procedure for deriving the "Grey box" transformer model in EMTP-RV.

4. CASE STUDY

The transformer models we developed are tested on several configurations. In the scope of this paper, the responses of the EMTP-RV models are investigated on two different cases: lightning impulse applied on phase A and C, phase B grounded with 400 Ω resistance, neutral grounded with 1000 Ω, secondary terminals isolated (case 1); lightning impulse applied on phase A and C, phase B grounded with 400 Ω resistance, neutral grounded with 1000 Ω, secondary terminals grounded with 250 nF capacitances (case 2);

The responses of the real transformer are also measured in the laboratory, for the same cases. To investigate the models accuracy, comparisons between the maximum values of transferred overvoltages calculated with the models in EMTP-RV and those obtained by the measurements, are presented. The values are given for each phase and case.

Table 1 - Comparison between simulation and measurements results (the values are given in percentage of the amplitude of the impulse applied at the primary terminals)

		Signal shape	a1 / %	b1 / %	c1 / %	a2 / %	b2 / %	c2 / %
case 1	Measurements	1,43/55 μs	69,3	18,5	43,6	70,1	18,6	44
	„Black box“	1,2/50 μs	70,0	17,8	40,0	68,4	19,5	44,6
	„Grey box“	1,2/50 μs	71,6	26,0	38,6	71,7	26,0	38,6
case 2	Measurements	1,4/42,2 μs	13,7	-13,2	1,0	13,7	-13,0	1,1
	„Black box“	1,2/50 μs	18,8	-16,9	1,7	18,4	-17,0	1,5
	„Grey box“	1,2/50 μs	16,3	-15,5	1,1	16,4	-15,5	1,1

Note that in the case study, measurement equipment is not modelled and the signal shape of the lightning impulse is ideal 1,2/50 μs wave. During the measurements the shape of the applied wave slightly differs from the ideal, as it can be seen from the table 1. Nevertheless, the models gave accurate amplitudes of the overvoltages transferred to the secondary side. Only noticeable difference between the measurements and the simulation results can be observed for the phases b1 and b2 in the case 1. This

can be explained through the fact that no interphase mutual (capacitances and inductances) are modelled in the Grey Box model. The shapes of the transferred waves are not in the scope of this paper. They will be studied in the future.

5. CONCLUSION

In this paper the “Black box” and the “Grey box” model of the 64 MVA distribution transformer is developed in EMTP-RV. “Black box” is based on FRA measurement (done with the equipment proposed in the Standard IEC 60071-18 [3]), rational approximation and state space equations. This model is used since it requires only the data measured from the transformer terminals, which is available to the power utility. “Grey box” is based on simple RLC network whose parameters are derived from the transformer window geometry and the nameplate data.

The models we developed gave an accurate response for the calculation of the maximum values of the transmitted overvoltages for the cases observed in this document.

In the future we will strive to analyze more measurements techniques for developing the “Black box” model and to include more details in the “Grey box” model such as additional elements like regulation windings, interphase inductances and capacitances and frequency dependence of the RLC components. These advanced models should help to detect a minimum knowledge on the transformer data required to build a transformer model accurate enough for a wideband frequency range, which is the aim of the research.

6. ACKNOWLEDGMENT

The authors express their thanks to Siemens Končar Power Transformers for providing the measurement results which were used for the development and validation of the models presented in this paper.

7. REFERENCES

- [1] CIGRE Working Group A2/C4.39, “Electrical transient interaction between transformers and the power systems” (2013.)
- [2] EMTP-RV documentation – www.emtp.com. (20th February 2014.)
- [3] International Standard IEC 60076-18: “Power Transformers – Part 18: Measurement of frequency response” (First edition, 2012.)
- [4] Filipovic-Grcic, D., Filipovic-Grcic, B., Uglesic, I., “High-Frequency Model of Power Transformer Based on Frequency Response Measurements” (IEEE PES Transaction on Power Delivery, Submitted for publishing, 2013.)
- [5] Gustavsen, B., “Wide band modeling of power transformers” (IEEE Transactions on Power Delivery, vol. 19, pp. 414-422, 2004.)
- [6] Legrand, X., Xemard, A., Nucci, C.A. and Auriol, P., “A Method to Interface Electromagnetic Models of Grounding Systems with Transients Programs” (CIGRE C4 Colloquium on Power Quality and Lightning, Sarajevo, May 2012.)
- [7] Jurisic, B., Xemard, A., Uglesic, I. and Paladian, F., “High frequency transformer model for calculations of transferred overvoltages” (CIGRE International Colloquium on Lightning and Power Systems, Lyon, May 2014.)
- [8] Bjerkan, E., “High frequency modeling of power transformers,” (PhD Thesis, 2005.)
- [9] Bjerkan, E. and Hoidalén, H.K., “High frequency FEM-based power transformer modeling: Investigation of internal stresses due to network-initiated overvoltages” (IPST 2005, Montreal, Canada, June 19-23, 2005.)
- [10] Uglesic, I., “Calculating Lightning Overvoltages Transferred through a Transformer” (Proceeding of 24th International Conference on Lightning Protection, UK, September 1998.)
- [11] Meeker, D., “Finite Element Method Magnetics” – www.femm.info/wiki/HomePage (17th February 2014.)
- [12] Gustavsen, B., Semlyen, A., “Rational approximation of frequency domain responses by vector fitting” (IEEE Transactions on Power Delivery, vol.14, no.3, pp.1052-1061, 1999.)
- [13] Gustavsen, B., “Improving the Pole Relocating Properties of Vector Fitting” (IEEE Transactions on Power Delivery, vol. 21, no. 3, pp. 1587-1592, July 2006.)

- [14] Ye, Z., Li, Y., Gao, M. and Yu, Z., "A novel framework for passive macromodeling" (48th IEEE Design Automation Conference, USA, 2011.)
- [15] Ye, Z., "pmm: A Matlab Toolbox for Passive Macromodeling in RF/mm-wave Circuit Design" (IEEE 10th International Conference on ASIC, 2013.)
- [16] Deschrijver, D., Mrozowski, M., Dhaene, T. and Zutter, D. D., "Macromodeling of Multiport Systems Using a Fast Implementation of the Vector Fitting Method" (IEEE Microwave and Wireless Components Letters, vol. 18, no. 6, pp. 383-385, June 2008.)
- [17] Grivet-Talocia, S. "Passivity enforcement via perturbation of Hamiltonian matrices" (IEEE Transactions on Circuits and Systems I: Regular Papers, vol.51, no.9, pp.1755-1769, 2004.)
- [18] Gustavsen, B., Semlyen, A., "Enforcing passivity for admittance matrices approximated by rational functions" (IEEE Transactions on Power Delivery, vol. 16, no. 1, pp. 97–104, 2001.)
- [19] Semlyen, A., Gustavsen, B., "A Half-Size Singularity Test Matrix for Fast and Reliable Passivity Assessment of Rational Models" (IEEE Transactions on Power Delivery, vol. 24, no. 1, pp. 345-351, January 2009.)
- [20] Gustavsen, B., "Fast Passivity Enforcement for Pole-Residue Models by Perturbation of Residue Matrix Eigenvalues" (IEEE Transactions on Power Delivery, vol. 23, no. 4, pp. 2278-2285, October 2008.)
- [21] Gustavsen, B., Semlyen, A., "Fast Passivity Assessment for S -Parameter Rational Models Via a Half-Size Test Matrix" (IEEE Transactions on Microwave Theory and Techniques, vol.56, no.12, pp.2701-2708, 2008.)
- [22] Meeker, D., "Finite Element Method Magnetics" (User's Manual Version 4.2, 2013.)