

Goran Plišić  
Končar Power Transformers Ltd  
goran.plisic@siemens.com

Kosjenka Capuder  
Končar Power Transformers Ltd  
kosjenka.capuder@siemens.com

## INFLUENCE OF WINDING CAPACITANCES TO GROUND MODELLING ON THE CALCULATION OF TRANSFERRED VOLTAGES IN POWER TRANSFORMER

### SUMMARY

During voltage transients, the windings of a transformer are coupled by electric and magnetic fields. To calculate the transients inside the transformer, a network model is typically used. The accuracy of obtained calculation results depends mainly on this model in which the windings are lumped into R, L and C circuit components. The windings are usually represented by discs, or groups of discs, with the corresponding resistances, inductances (self and mutual) and capacitances (series and to the ground) [1]. In case of impulse voltage, wave's steep front and consequently high frequency oscillations are the main reason why capacitances modelling is of major importance for the calculation of voltage distribution in winding and between windings.

**Key words:** power transformer, overvoltages, lightning, capacitances, model, 3D FEM

### 1. INTRODUCTION

In order to calculate the transient and oscillatory responses of windings to impulse waves, the appropriate model of the transformer is used in practice. It includes inductances and capacitances of the windings and resistive elements as representation of damping. Finally, a network of finite number of lumped elements is formed. The inductive network consists of branches and nodes, with each branch between two neighbouring nodes. The lumped capacitances are then assigned to the nodes. There are capacitances between nodes, as well as between nodes and ground (Figure 1). To ensure validity of the circuit for the requested calculations, the model complexity is chosen to accurately represent behaviour in the frequency range of interest. It means that one element of lumped parameters is small enough to correctly represent oscillations with this frequency. In this case the biggest elements are discs in a disc winding and with this specific geometry the calculation is valid for a range of frequencies up to several hundreds of kHz.

During some special impulse voltage tests in the factory measurements of transferred voltages between windings of a transformer were conducted. HV side was impulsed on two phases simultaneously and LV side voltages were measured. Tests included different combinations of grounding of HV and LV terminals to correspond to realistic situations occurring during transformer operation in a power system.

Comparison with the calculation showed some deviation. After analysis of all the results and influences, especially focused at different grounding combinations, the idea was to check modelling of capacitances. The emphasis is on shunt capacitances since, as stated in [2], even the bushing and terminal bus capacitances have the effect of reducing the transferred electrostatic component of voltage. This is also valid for the other capacitances to metal parts in the vicinity of windings / winding connections. To check the adequacy of existing analytical calculation of capacitances a 3D transformer model was built and capacitances of interest were calculated using FEM (finite element method) software, Ansys Maxwell (v.15).

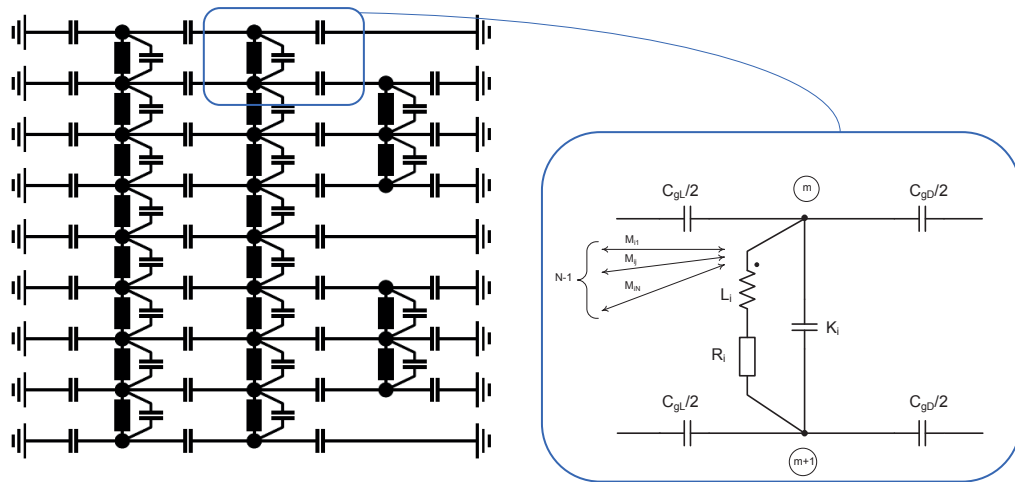

Figure 1 – simplified, one phase network model with lumped elements

- $K_i$  – series capacitance of the element "i"
- $R_i$  – resistive component of the element "i"
- $L_i$  – self inductance of element "i"
- $M_{ij}$  – mutual inductances between elements "i" and "j"
- $C_{gL}$  – shunt capacitance between element "i" and left neighbouring element or earth
- $C_{gD}$  – shunt capacitance between element "i" and right neighbouring element or earth

As mentioned, two phases are impulsed at the same time, so for this specific case, a three phase model is needed. This means that three one-phase models are connected to form a three-phase model while basic principle of the network per phase stays the same. Also, there are some capacitances modelled between windings of neighbouring phases.

## 2. CAPACITANCES

### 2.1 Standard, analytical model

#### 2.1.1 Series Capacitances

Values of series capacitances are calculated as equivalent capacitances based on the electrostatic energy stored in the network of elementary capacitances. In the described model the details include elementary turn-to-turn and disc-to-disc capacitances and their connection depending on a type of winding [3]. These capacitances will not be tested in this paper.

#### 2.1.2 Shunt Capacitances inside one phase

Capacitances between winding and core, neighbouring windings and winding and tank are calculated with simple analytical formulas for capacitance between concentric cylinders:

$$C = 2\pi\epsilon_0\epsilon_r \frac{H}{\ln \frac{D_2}{D_1}} \quad (1)$$

- Where:
- $\epsilon_0$  - permittivity of vacuum ( $\epsilon_0 = 8.854 \text{ pF/m}$ )
  - $\epsilon_r$  - relative permittivity of the relevant material between electrodes
  - $H$  - length of cylinder (m) (electrical winding height)
  - $D_2$  - diameter of outer cylinder (inner diameter of outer winding)
  - $D_1$  - diameter of inner cylinder (outer diameter of inner winding)

Similar formula, with some corrective factors, is in the used transient calculation. Corrective factors are taking into account the real geometry with conductor insulation and radial ducts.

### 2.1.3 Shunt capacitances between phases

Similarly to the ones described in previous paragraph, capacitances between windings of neighbouring phases are calculated with analytical formula for capacitance between parallel cylinders:

$$C = \frac{\pi \varepsilon_0 \varepsilon_r H}{\ln \left( \frac{a}{D} + \sqrt{\left( \frac{a}{D} \right)^2 - 1} \right)} \quad (2)$$

Where:  $a$  - distance between cylinders' (windings') axes  
 $D$  - outer diameter of cylinders

However, formulas for shunt capacitances are used for all the lumped elements regardless of their position in the transformer core window. So, in this case even the 2D FEM (or BEM) would be an improvement, keeping in mind to avoid errors when using 2D rotational symmetric model, since it doesn't describe the transformer core/yoke in the right way. In addition to the aforementioned capacitances of windings, there are also capacitances of winding connections that are not taken into account. They can also influence the result. Winding connections are typically a geometry that is difficult, if not impossible, to represent and calculate in 2D.

### 2.2 3D FEM model

To check the adequacy of existing analytical approach, 3D FEM calculation is chosen since it allows simultaneous solution to the mentioned capacitances with one model.

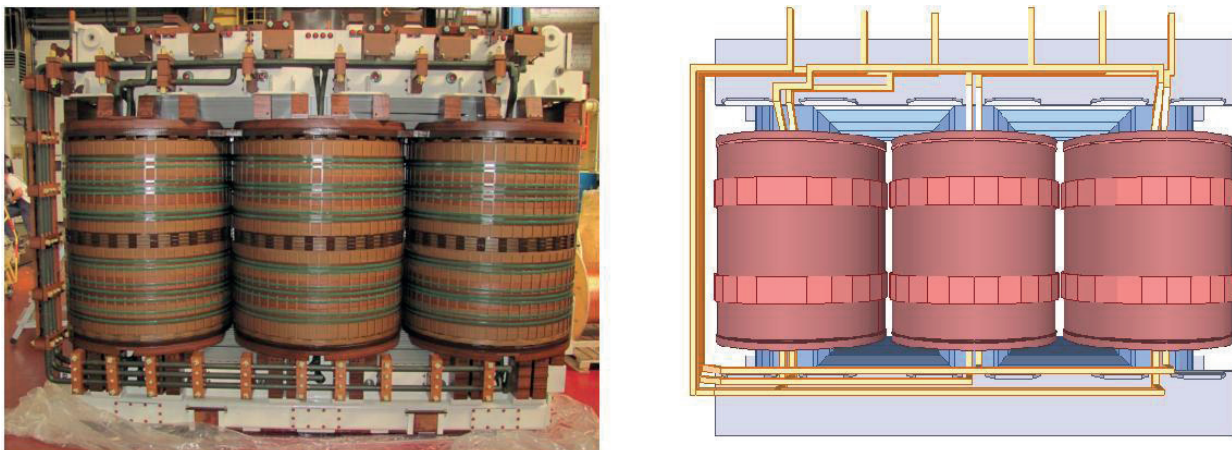

Figure 2 – Transformer active part in the production / 3D transformer model in Ansys Maxwell v.15

FEM Model (shown in Figure 2) consisted of the transformer active part in the tank, including LV side winding connections. Insulation cylinders between windings, as well as some wooden parts near the windings were modelled. Permittivity used in the model:

Table I – permittivity values used

$\varepsilon_r, oil$	$\varepsilon_r, paper$	$\varepsilon_r, transformerboard$	$\varepsilon_r, wood$
2.2	3.4	4.4	4.4

Because of the size of the model and large differences in dimensions, one compromise that had to be done is that only end parts of windings were modelled to the size of disc/turn, and not the whole winding height. Otherwise the model would become too large and the calculation too slow on available computer resources. Nevertheless, from the results shown, it can be seen that the assumption of homogeneity of field is proved valid, when going deeper in the winding. In Figure 3 an illustration of voltage distribution is given looking at intermediary results obtained when calculating capacitances. Maxwell 3D software allows

user to generate capacitance matrix from chosen electrodes, so this part of work was straightforward and easy to accomplish.

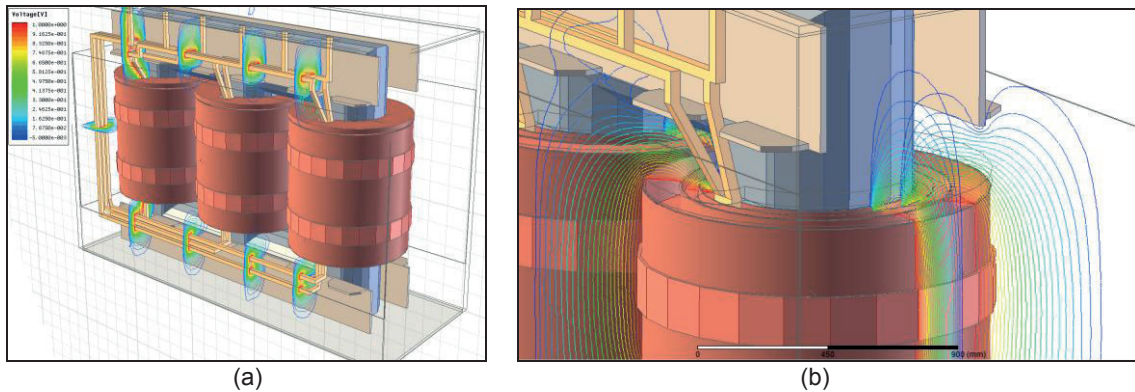

Figure 3 – Illustration of voltage distribution around electrodes of interest – (a) LV winding connections, (b) windings

### 3. RESULTS

#### 3.1 Capacitances

The main differences between two calculations are in the parts where electric field is not homogeneous and areas which are not covered with analytical expressions at all. That said, it's obvious that winding ends, top and bottom, are the places to look at. Main differences are shown in Tables II and III. Shunt capacitances between windings and grounded parts are shown with results given for top part since bottom is nearly the same.

Table II – Capacitances between turns of LV winding and ground

Turns, top to bottom	Analytical formula	FEM 3D	
	$C_r$ in pF	$C_r$ in pF, phases 1,3	$C_r$ in pF, phase 2
Turn 1	60,1	133,2	130,3
Turn 2	60,1	58,6	58,9
Turn 3	60,1	58,9	59,0
Turn 4	60,1	59,6	59,2
Turn 5	60,1	59,5	59,2
Turn 6	60,1	59,5	59,1
Rest, average per turn	60,1	59,8	59,4

Table III – Capacitances between discs of HV winding and ground

Discs, top to bottom	Analytical formula	FEM 3D	
	$C_r$ in pF	$C_r$ in pF, phases 1,3	$C_r$ in pF, phase 2
Disc 1	5,76	103,5	116,2
Disc 2	5,76	10,6	12,0
Disc 3	5,76	7,3	8,5
Disc 4	5,76	6,4	7,5
Disc 5	5,76	6,0	7,1
Disc 6	5,76	5,7	6,7
Rest, average per disc	5,76	5,3	5,5

LV winding connections in this specific transformer are of such configuration, which can be seen in Figure 2, that their capacitances are not negligible, especially if we compare values with those inside windings. Capacitances between LV winding connections and connections to the ground are shown in Table IV.

Table IV – Capacitances between LV winding connections and to the ground (FEM 3D)

<b>LV1 :</b>	a1-b1	a1- c1	b1-c1	a1-ground	b1-ground	c1-ground
C in pF	142,44	25,51	81,08	159,52	110,55	123,36
<b>LV2 :</b>	a2-b2	a2-c2	b2-c2	a2-ground	b2-ground	c2-ground
C in pF	291,31	47,04	317,99	325,40	156,35	328,42

### 3.2 Measurement

Equipment used for the measurement was:

- Haefely Recurrent Surge Generator (RSG), type 481
- Tektronix Digital Oscilloscope, type TDS 544A, 1Gs/sec

The transformer is 64MVA, 24/6,8/6,8 kV, connection YNd11d11. Test connection is shown in Figure 4, with possible values of capacitances C of 250 and 500 pF, and resistance R of 600 and 1000  $\Omega$ .

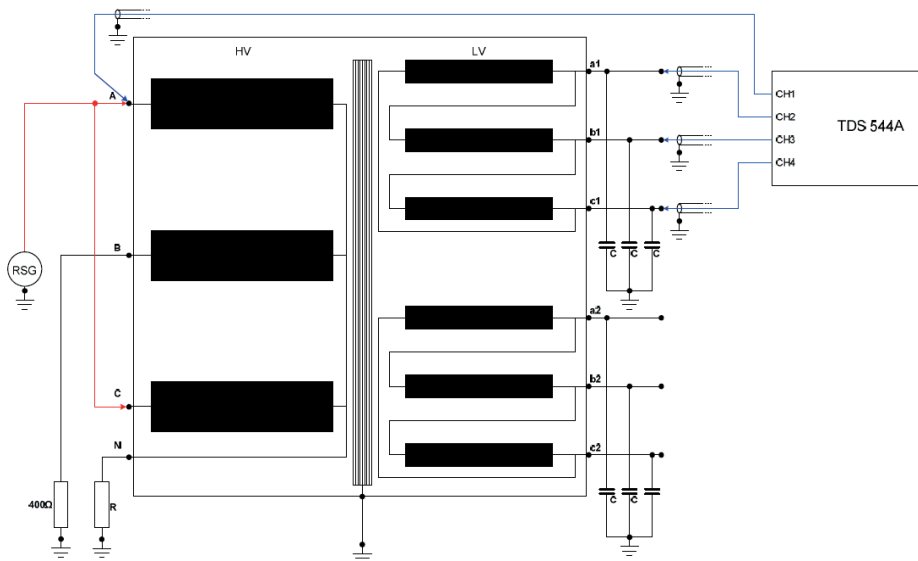

Figure 4 – Test connection for RSO measurement

### 3.3 Transient calculation

To check the influence of corrected or newly added capacitances one case from the measurements is chosen, the case with all of the LV winding terminals being isolated and HV neutral grounded with 600  $\Omega$ .

Table V gives a comparison between voltages calculated on LV side with, in the first case, capacitances calculated according analytical expressions and, in the second, those obtained from 3D FEM calculation.

Table V – Maximum voltages on LV windings terminals (in percent of impulse voltage on HV side)

<i>terminal</i>	<i>Measurement</i>	<i>Standard transient calculation</i>	<i>Calculation with FEM 3D capacitances</i>
	<i>U in %</i>	<i>U in %</i>	<i>U in %</i>
a1	68,0	73,0	69,1
b1	15,7	20,0	18,9
c1	41,9	45,4	43,2
a2	68,9	73,9	68,2
b2	16,6	21,4	19,3
c2	42,5	46,4	40,8

In Figures 5 to 10, calculated voltage waveshapes of LV windings terminals are shown in comparison to measurement. Influence of capacitances values on amplitudes and waveshapes is clearly seen. In this case it's more visible on the LV2 side (terminals a2, b2, c2) which can be explained with higher values of capacitances of windings connections.

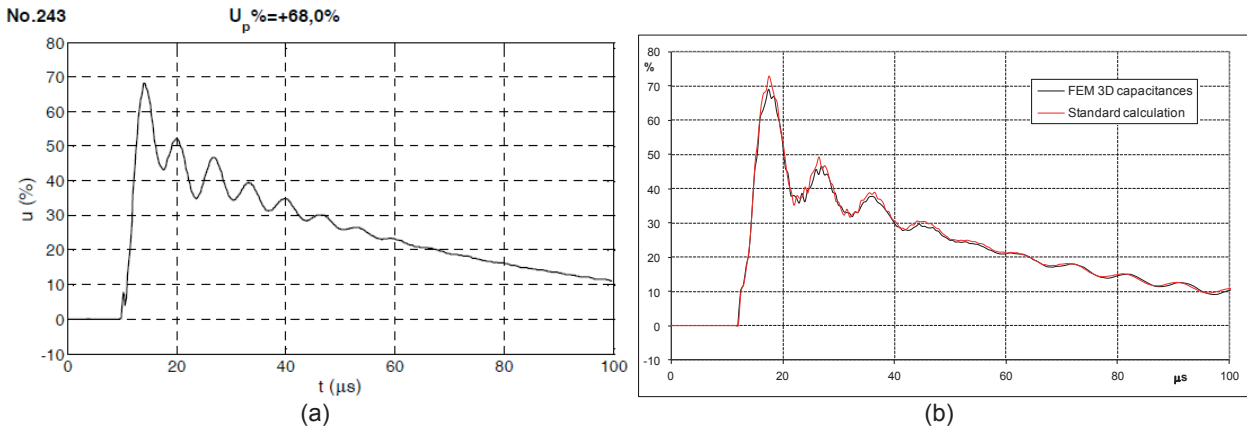

Figure 5 – Measured (a) and calculated (b) voltage waveshape on terminal a1

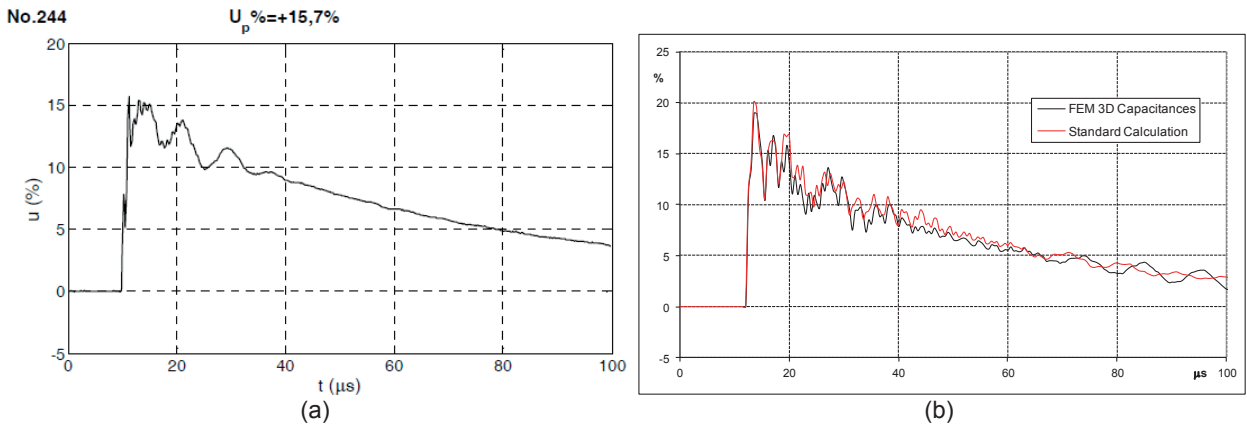

Figure 6 – Measured (a) and calculated (b) voltage waveshape on terminal b1

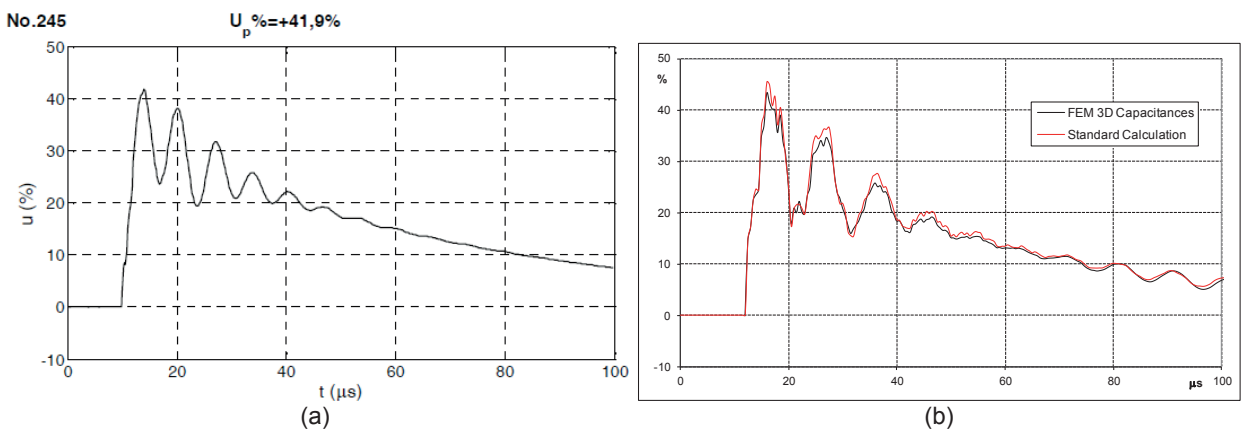

Figure 7 – Measured (a) and calculated (b) voltage waveshape on terminal c1

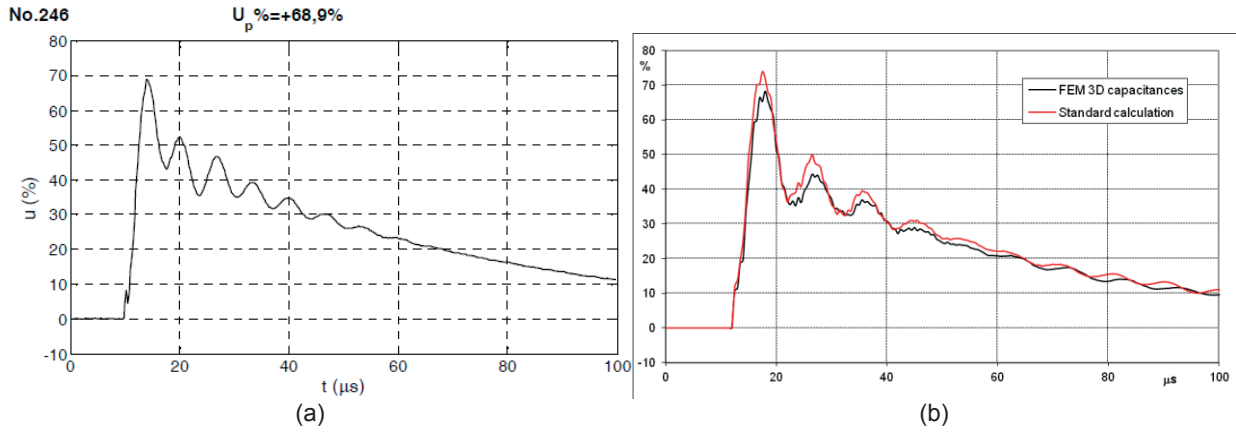

Figure 8 – Measured (a) and calculated (b) voltage waveshape on terminal a2

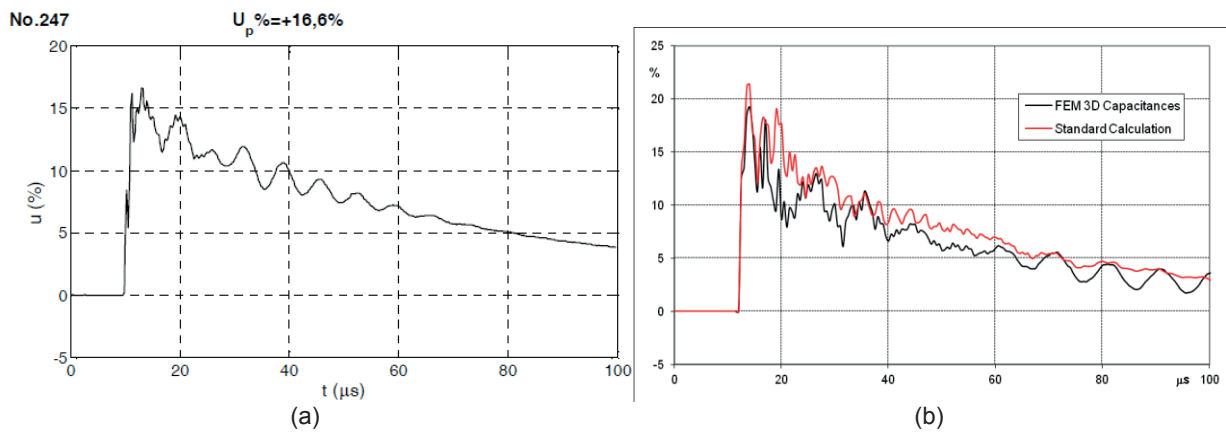

Figure 9 – Measured (a) and calculated (b) voltage waveshape on terminal b2

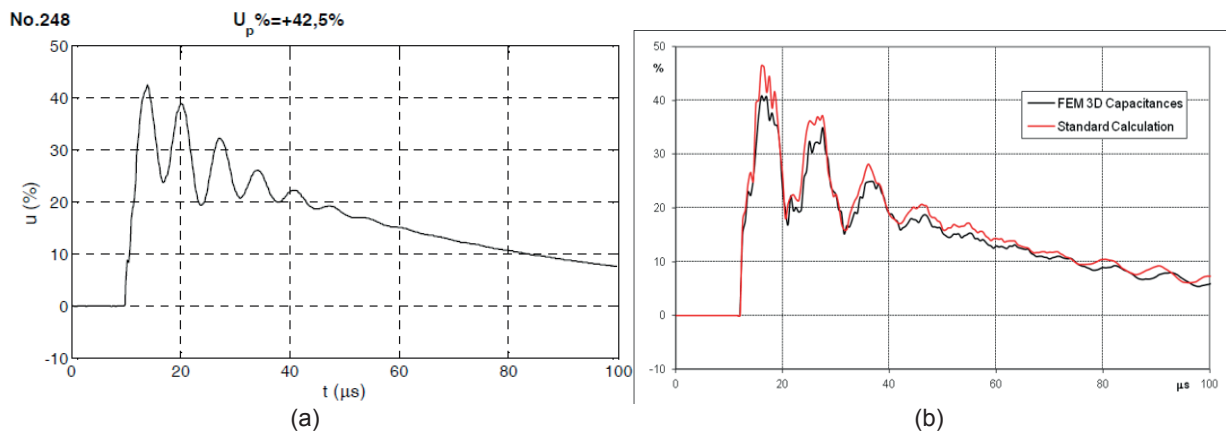

Figure 10 – Measured (a) and calculated (b) voltage waveshape on terminal c2

#### 4. CONCLUSION

The main idea behind the influence of capacitance modelling on transferred overvoltages has been described through one example. The results showed the importance of adequate modelling of capacitances that are not usually taken into account or their influence is underestimated. This includes shunt capacitances of windings to grounded parts (i.e. core, clamping plates, tank etc.) and capacitances of winding connections to each other and to ground too. Influence on the final result, i.e. transferred voltages, was shown with transient calculation and two different sets of capacitance values (standard and FEM based) while other parameters remained the same. Transient calculation results were compared to

measurement and both the amplitudes as well as voltage waveshapes showed good agreement, especially after corrected capacitance values have been introduced. If we look at the difference (in percent) of all calculated values to measurement, their root mean square value went down from 17.5% to 10.9% with FEM 3D calculated capacitances. This puts the calculation results practically in the area of measurement uncertainty.

It was once again confirmed that FEM 3D analysis, although powerful, for certain problems is too time consuming, while the results obtained can be reached through simpler methods, but with appropriate complexity. For the future analyses the solution may be in using some of the capacitive weighting techniques as mentioned in [4].

## 5. REFERENCES

- [1] V. Kulkarni, S. A. Khaparde, *Transformer Engineering: Design and Practice*, Marcel Dekker, Inc., 2004
- [2] Abetti, P.A., *Electrostatic voltage distribution and transfer in three-winding transformers*, AIEE Transactions, December 1954, p. 1407–1416.
- [3] Ambrozic, C., *Berechnung der Ersatzkapazität einer Scheibenspule von einer Normalscheibenspule-transformatorwicklung*, *Etz-A*, Vol. 93, No. 8, 1972, pp.446-450
- [4] Adam J. Thomas, Satish M. Mahajan, *Capacitive weighting technique for estimating the 3D turn-level capacitance in a transformer winding*, *Electric Power Systems Research* (2011), vol. 81 issue 1 p. 117-122
- [5] Robert M. Del Vecchio, Bertrand Poulin, Pierre T. Feghali, Dilipkumar M. Shah, Rajendra Ahuja, *Transformer design principles, with applications to core-form power transformers*, second edition, Taylor and Francis Group, LLC, 2010
- [6] M. Popov, L. van der Sluis, R.P.P. Smeets, *Evaluation of surge-transferred overvoltages in distribution transformers*, *Electric Power Systems Research* (2008) vol. 78 issue 3 p. 441-449