

ZORAN ZBUNJAK

zoran.zbunjak@hops.hr

HOPS Croatian Transmission System Operator Ltd.

HRVOJE BAŠIĆ HRVOJE PANDŽIĆ IGOR KUZLE

hrvoje.basic@fer.hr hrvoje.pandzic@fer.hr igor.kuzle@fer.hr

**University of Zagreb Faculty of Electrical Engineering
and Computing**

PHASE SHIFTING AUTOTRANSFORMER, TRANSMISSION SWITCHING AND BATTERY ENERGY STORAGE SYSTEMS TO ENSURE N-1 CRITERION OF STABILITY

SUMMARY

Since the portion of non-dispatchable renewable generators in the system is increasing, several challenges to the safety and stability of the power system have arisen. The focus of this paper is analyzing local congestion effects in the system by using three distinct methods: phase shifting autotransformer, transmission switching and battery energy storage system. This work includes a review of the congestion management techniques and the results of simulations that utilize phase shifting autotransformer to reduce power flows in the network, and transmission switching and battery energy storage system in order to ensure N-1 stability criterion in case of malfunction of the integrated autotransformer. Power system is modelled and simulated using Power Transmission System Planning Software, a software tool for electric transmission system analysis and planning. Results of simulations are presented, a thorough analysis of the results is performed and justification of investments in proposed methods is elaborated.

Key words: Battery energy storage, N-1 criterion, phase-shifting autotransformer, transmission switching.

1. INTRODUCTION

Generally, high penetration of non-dispatchable renewable generation calls for more reserves to control frequency and perform voltage regulation in the system. Locally, it is more difficult to ensure N-1 stability criterion in areas with low consumption and high renewable generation because of increased power flow through transmission lines. Increased power flow issues can traditionally be solved by building new transmission lines or by revitalizing the existing transmission lines with new lines of higher transmission capacity. This solution can be considered as a long-term solution, but several constraints of power network can make it inefficient or even technically infeasible. In areas with rare or occasional high power flow, additional transmission lines can cause higher losses because of underloaded transmission lines, resulting in higher inductions of reactive power and very high voltage levels in the network. Additionally, building a new transmission lines can be complicated because of geographical constraints and legal affairs.

Because of all the above, different solutions to mitigate high power flow issues are presented in this work: integration of phase shifting autotransformer to redirect power flow, usage of transmission switching and integration of battery energy storage systems in order to ensure N-1 stability in case of an outage of any single network element.

Case studies presented in this study are based on a real part of Croatian power system, where a complex combination of variations in power flow, generation from hydroelectric and wind power plants and non-consistent consumption during the year makes this area challenging to operate.

The following section provides a literature review on the existing research and practical solutions in applications of phase shifting autotransformer, transmission switching and integration of battery energy storage systems. Region of the Croatian power system observed in this work is described in section Description of modelled region of the Croatian power system. In section Model description, the model of network transmission system is presented. Simulations of methods to reduce power flow and ensure n-1 criterion are presented and analyzed in section Simulation of different case studies, through four case studies. Model of network transmission system is modelled and simulated using Power Transmission System Planning Software (PSS®E) [1], a software tool for electric transmission system

analysis and planning. A thorough analysis is performed and some relevant conclusions are duly drawn.

2. TECHNICAL WORK PREPARATION

2.1. Phase Shifting Autotransformer

Transformers in power systems are primarily used to transport electric power between two different voltage levels. Their ability of regulating voltage magnitude and voltage phase angle between two different voltage levels ensures them a significant role in regulation of the power system. Voltage magnitude regulation transformers are used to control the reactive power flow in the system, while voltage phase angle regulating transformers are used to control the active power flow in the system. Phase shifting transformers are used in power systems to control the active and reactive power flow because they have the ability or regulating both voltage phase angle and voltage magnitude.

2.2. Transmission switching

Transmission switching is a tool that can be used to solve various problems in transmission system. According to reference [2], it can be used as a corrective mechanism to tackle line overloading, voltage violations and even for co-optimal generation with network topology rescheduling. It can also be used to modify network topology after outages of lines in the network, to improve efficiency of the transmission system and reduce generation costs, to ensure N-1 criterion, and as a congestion management tool.

Reference [3] describes a mixed-integer linear program for minimizing load shedding after applying a set of contingencies that can cause violations of the operation constraints. N-1 criterion was not described, and the proposed model is proven to be the most effective for high and low transmission loading conditions.

Optimal power flow problem, formulated as a mixed-integer linear program, is often used in research and operation for mathematical modelling of networks in steady state. Its application provides reliable and usable results, but in some cases it can cause system security issues as a result of angular security. Authors in [4] extend the optimal power flow problem with N-1 and voltage constraints and binary variables to satisfy N-1 and voltage security criteria.

2.3. Battery energy storage systems

The idea of integration of battery energy storage in power systems with the purpose of providing services for increasing safety has recently become relevant for real-life applications, since technologies for storing energy have become more

technologically improved and economically attractive. However, literature on integration of battery energy storage in power systems to ensure N-1 criterion is quite scarce, although there are many available information and results of research on the power system safety, N-1 criterion and integration of energy systems to provide ancillary services to the power system.

In [5] a technique for optimal integration battery energy storage system in the transmission network, based on mixed-integer linear program with lossless dc representation, is presented. A technique is divided in three stages: in the first stage optimal siting's for integration are located, in the second sizing's of battery energy storages are defined, and in the third technical characteristics, capabilities and constraints of the power system and battery energy storages are introduced.

In [6], a comparative analysis of the economic and technical benefits of energy storage and N-1 network security in transmission expansion planning, based on mixed-integer linear programming approach, is performed. This analysis indicates that investment costs and generator operating costs can be reduced by integration of energy storage system into the network planning procedure, while respecting the N-1 criteria.

Enhancement of security-constrained optimal power flow with distributed battery energy storage for post-contingency power flow corrective control is proposed in [7]. The authors conclude that implementation of the proposed idea increases the utilization of transmission lines bringing them closer to their economic optimum. In [8], the authors extend the security-constrained optimal power flow model from [7] with utility-scale storage units to the unit commitment model, aiming to reduce operating costs by using storage units to reduce operating costs and for corrective control actions. Security-constrained optimal power flow is formulated as a large two-stage mixed-integer programming problem and solved using Benders' decomposition method.

Based on the literature review, dealing with increased power flows and congestion issues is a well-known problem in research community. The specific contribution of this paper is in evaluating different combinations of the proposed solutions, comparison of benefits and drawbacks of each solution and simulation of the proposed solution on a model of part of a real power system.

3. DESCRIPTION OF MODELLED REGION OF THE CROATIAN POWER SYSTEM AND MODEL DESCRIPTION

The main characteristic of the Croatian power transmission system are high power flows from the south to the north of country, especially in hydrologically favorable conditions. Large hydroelectric power plants are located in the south of the country, while most of thermal power plants are located in the north, continental part of the country. Scheme of the modelled region of the Croatian power system is shown in Fig. 1. Wind farm Vrataruša, with a total installed capacity of 42 MW, is situated in the described south-north corridor. Its variable

and heavily planned generation can cause certain issues in the 110 kV part of the power transmission network. Wind power plant Vrataruša is located on an already heavily loaded 110 kV corridor between two hydroelectric power plants Senj (210 MW) and Vinodol (85 MW). With full engagement of hydro power plant Senj and wind power plant Vrataruša, 110 kV transmission line Crikvenica - Vrataruša can be overloaded. Different scenarios for mitigating this problem are analyzed through the rest of paper.

The focus of this work is mitigation of local congestion caused by non-dispatchable renewable generators and ensuring N-1 criterion.

A real part of the Croatian power system with existing problems of ensuring N-1 security criterion after integration of wind generation in the area is modelled and simulated in PSS®E.

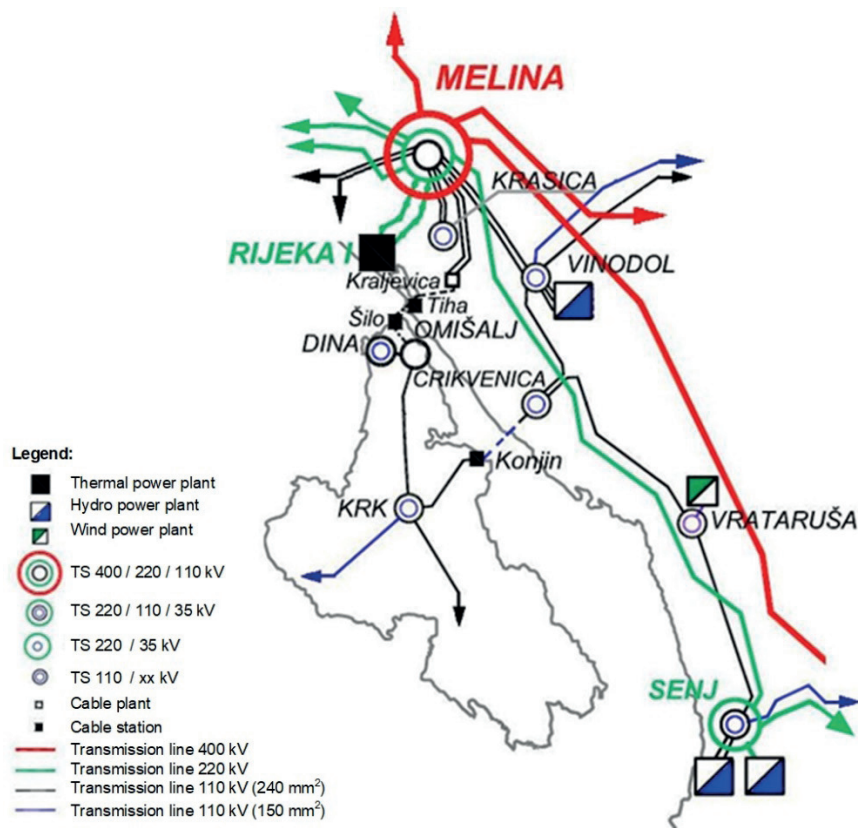

Figure 1. Power system scheme

4. SIMULATION OF DIFFERENT CASE STUDIES

The base case is representing the worst scenario captured in the real world, with the highest active power flow through transmission lines in the area, caused by high generation of hydro and wind generators in the area. Case study 1 presents

the long-term solution to possible congestions in transmission lines, integration of phase shifting autotransformer. Since n-1 criterion would not be ensured in case of outage of the integrated autotransformer, possible scenario of violation of n-1 criterion is shown in case study 2. Several solutions to reduce active power ensure n-1 criterion after outage of the autotransformer are presented in case studies 3, 4 and 5, as shown in Table I.

Table I. Case studies

Case study	Description
Base case study	The worst scenario from the real world, with the highest active power flow through transmission lines
Case study 1	Integration of phase shifting autotransformer to reduce active power flow
Case study 2	Example of N-1 criterion violation – outage of the autotransformer
Case study 3	Transmission switching to ensure N-1 criterion after outage of the autotransformer
Case study 4	Integration of battery energy storage to ensure N-1 criterion after outage of the autotransformer
Case study 5	Combination of integration of battery energy storage and transmission switching to ensure N-1 criterion after outage of the autotransformer

4.1. Base case study

In the base case, the transformer is operating in the voltage magnitude regulation mode, battery energy storage at busbar Vrataruša is not connected and all transmission lines are in operation, so power flow from/to other areas is fully enabled. Active power flow through transmission power lines in the presented area is shown in Fig. 2. It is shown that transmission line 110 kV Vrataruša – 110 kV Crikvenica is loaded at 108,1 MW (89,2 %) and that N-1 criterion is not ensured in case of failure of a bulk element in the area.

As mentioned in introduction, building a new transmission line or increasing the capacity of the existing line is not considered as an economically feasible solution because it would operate in underloaded mode most of the time, thus already high voltages in this area of the network would further increase. Therefore, we consider integration of phase shifting autotransformer, integration of battery energy storage and performing transmission switching.

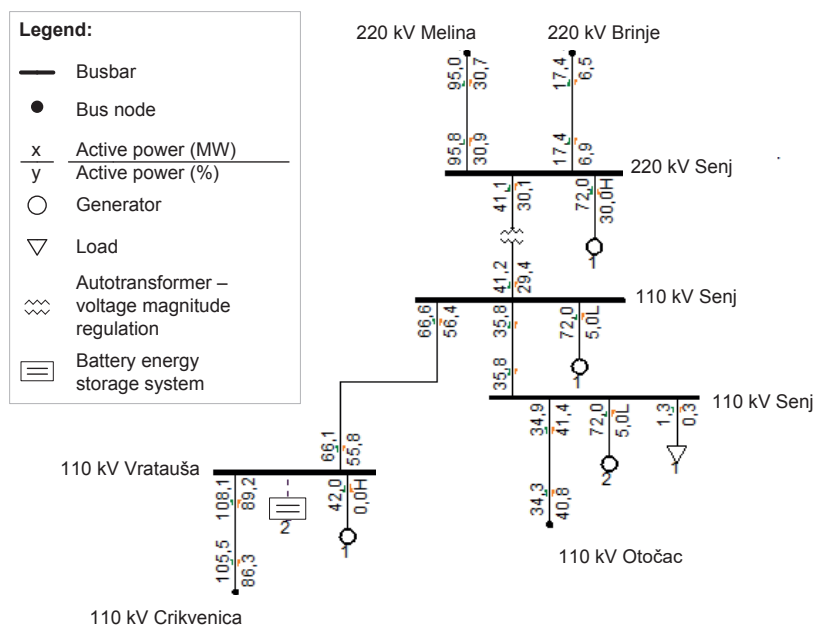

Figure 2. Active power flow in transmission power lines in the considered sub-network (base case)

4.2. Case study 1

Integration of a phase shifting autotransformer is presented as a good solution to reduce active power flow in transmission lines. In Fig. 3, the results show that a high percentage of active power flow is redirected from the highly loaded 110 kV to the 220 kV network, and thus possible congestion and violation of N-1 criterion in 110 kV network are reduced. Active power flow through the endangered transmission line reduces from 108,1 MW (89,2 %) to 54,8 MW (48,8 %). It is important to notice that the N-1 criterion issue is still present in case of an outage of the phase shifting autotransformer or in case of increased power flows in 220 kV network.

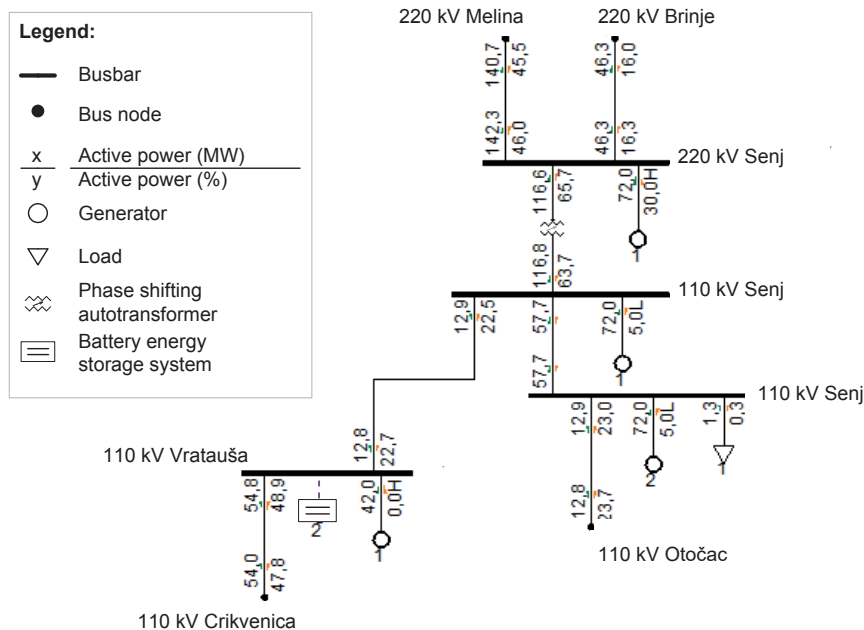

Figure 3. Integration of phase shifting autotransformer to reduce active power flow in 110 kV transmission network (Case study 1)

4.3. Case study 2

Active power flow in the presented area after an outage of the phase shifting autotransformer is shown in Fig. 4, where endangered transmission line 110 kV Vrataraša – 110 kV Crikvenica is overloaded at 137,2 MW (111,8 %).

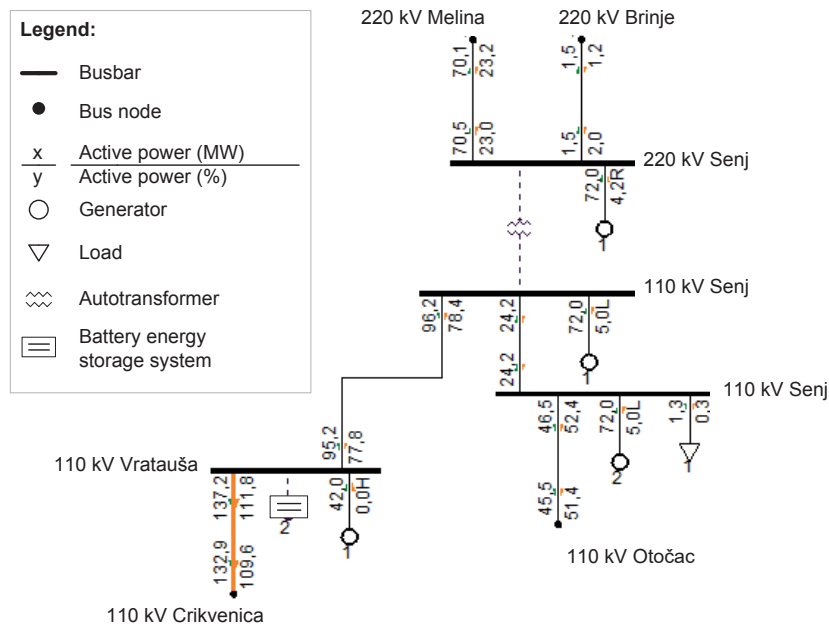

Figure 4. Example of a violation of the N-1 criterion - congestions of active power flow in transmission power lines after an outage of the autotransformer (case study 2)

There are several possible solutions to ensure N-1 criterion in the area. Replacing or upgrading the existing transmission lines with lines of higher capacity would resolve the issues of congestion and even N-1 criterion, but it would cause additional losses during most of the operating hours. In this work, two other solutions to ensure N-1 criterion are analyzed: transmission switching and battery energy storage.

4.4. Case study 3

In Fig. 5, performing transmission switching after an outage of the autotransformer (shown in Fig. 4) is presented. After separation of busbars, power flows are modified according to the Kirchhoff's voltage law, where load of transmission line 110 kV Vratauša – 110 kV Crikvenica is reduced to 113,4 MW (92,4 %). Even though the results are satisfactory, transmission switching can only be used in limited number of cases when conditions in network allow, thus it cannot be considered as the long-term solution.

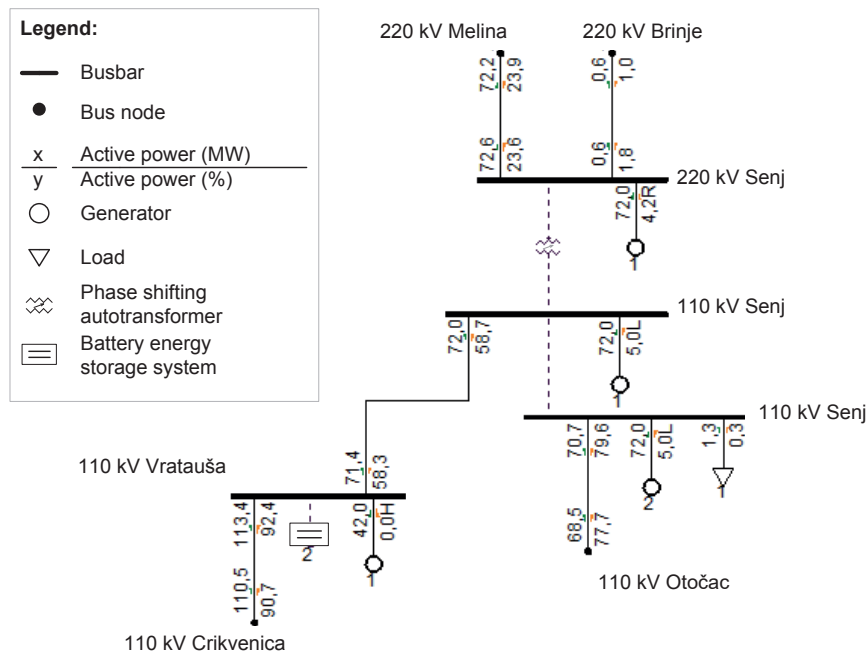

Figure 5. Transmission switching after an outage of the autotransformer to ensure N-1 criterion (case study 3)

4.5. Case study 4

Integration of 20 MW battery energy storage system at one end of transmission line 110 kV Vrataruša – 110 kV Crikvenica after an outage of the autotransformer, to ensure N-1 criterion, is shown in Fig. 6. Battery energy storage in this case operates as a consumer that stores limited amount of energy. Thus, battery storage system capacity should be carefully dimensioned according to history data and future plans of generation and consumption in the area. Detailed and optimal calculation of the capacity of the battery energy storage is not a part of this work because only static analysis of power flow is simulated. It is shown that battery energy storage system reduces the loading of transmission line 110 kV Vrataruša – 110 kV Crikvenica to 121,7 MW (99,3 %).

4.6. Case study 5

Combination of integration of 20 MW battery energy storage at one end of transmission line 110 kV Vrataruša – 110 kV Crikvenica and performing transmission switching after an outage of the autotransformer, to ensure N-1 criterion, is shown in Fig. 7. It is shown that this combination reduces the loading of transmission line 110 kV Vrataruša – 110 kV Crikvenica to 93,4 MW (76,1 %).

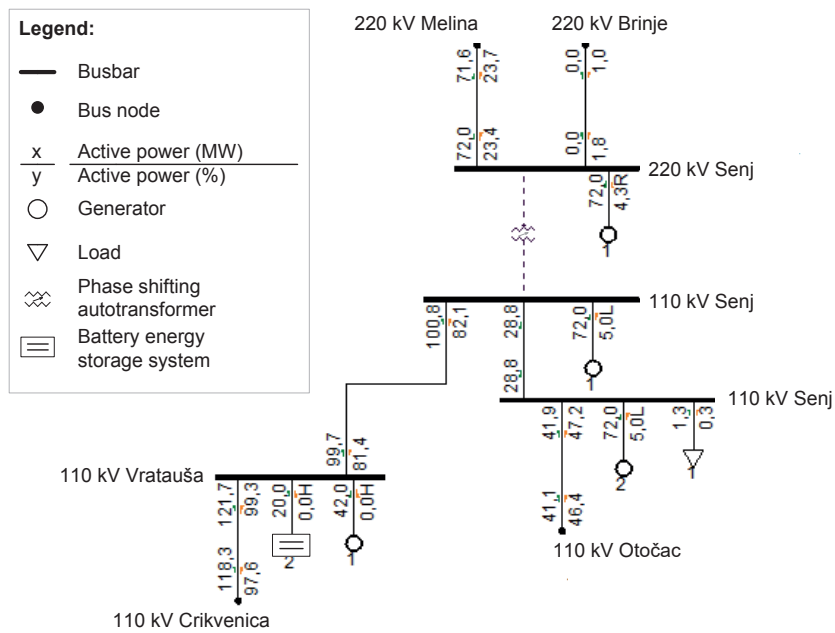

Figure 6. Integration of battery energy storage system after an outage of the autotransformer to ensure N-1 criterion (case study 4)

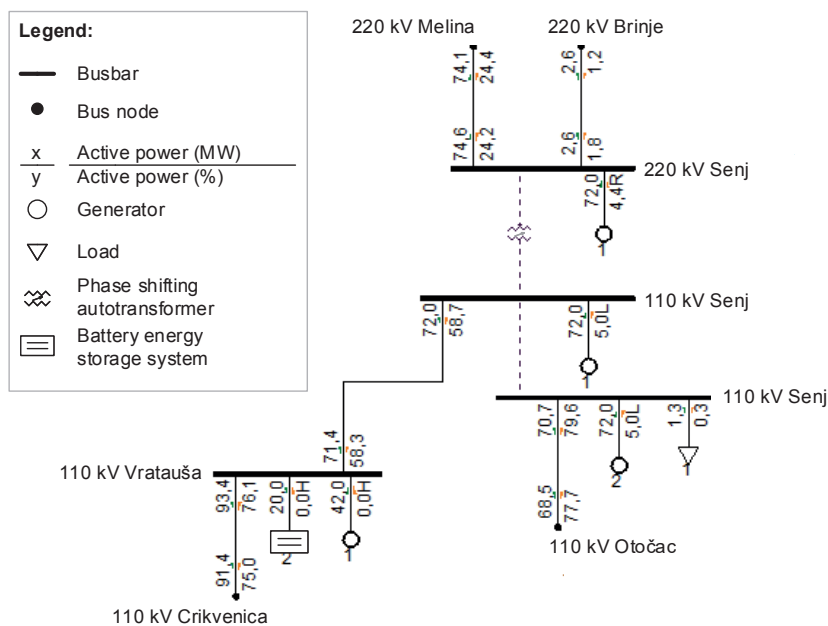

Figure 7. Combination of integration of battery energy storage system and transmission switching after an outage of the autotransformer to ensure N-1 criterion (case study 5)

4.7. Analysis of the simulation results

Results from simulations of all case studies are presented in Table II, where the endangered transmission line 110 kV Vrataruša – 110 kV Crikvenica is bolded.

Table II. Active power flow for all simulated case studies

Transmission line	Active power flow (%)					
	Base case study	Case study 1	Case study 2	Case study 3	Case study 4	Case study 5
220 kV Melina – 220 kV Senj	- 30,7	-45,5	- 23,2	- 23,9	- 23,7	- 24,4
220 kV Brinje – 220 kV Senj	- 6,5	- 46,3	1,2	0,6	0	1,2
220 kV Senj – 110 kV Senj 1	- 30,1	- 65,7	0	0	0	0
Bus coupler 110 kV Senj	- 23,86	- 38,47	- 16,13	0	- 19,2	0
110 kV Senj 1 – 110 kV Vrataruša	56,4	22,5	78,4	58,7	100,8	58,7
110 kV Vrataruša – 110 kV Crikvenica	89,2	48,8	111,8	92,4	99,3	76,1
110 kV Vrataruša – Battery energy storage system	0	0	0	0	- 100	- 100
110 kV Senj 2 – 110 kV Otočac	41,4	23,0	52,4	70,7	47,2	79,6

After integration of the phase shifting autotransformer in case study 1 more power is evacuated through transmission lines 220 kV Melina – 220 kV Senj and 220 kV Brinje – 220 kV Senj, which reduces the loading of the endangered transmission line 110 kV Vrataruša – 110 kV Crikvenica. Still, after an outage of the integrated autotransformer, transmission line 110 kV Vrataruša – 110 kV Crikvenica is overloaded at 111,8 % of nominal power flow. In case studies 3 and 4, usage of transmission switching and integration of battery energy storage system used separately reduces power flow through the endangered transmission line below 100 %. Combination of transmission switching and integration of battery energy storage in case study 5 gives the best result since the power flow through the endangered transmission line is reduced to 76,1 %.

Approximate investment costs based on the existing studies and evaluations are presented in Table III.

Table III. Investment costs for all case studies

Case study	Approximate investment costs (€)
Base case study	7.500.000
Case study 1	3.000.000
Case study 2	/
Case study 3	0

Case study 4	56.000.000
Case study 5	56.000.000

Investment costs for battery energy storage are based on [9], where the investment costs are evaluated to 2.800 € per 1 kW. Therefore, the 20 MW battery energy storage the investment cost is estimated to 56.000.000 € in case studies 4 and 5. Investment costs in the base case scenario, for building new transmission lines, are evaluated based on information from [10], where the costs are evaluated at 2.500.000 € per 10 km of 110 kV transmission line. Transmission line 110 kV Vrataruša – 110 kV Crikvenica is approximately 30 km long, so overall costs for building new transmission line are evaluated at 7.500.000 €. It is important to notice that investment costs for increasing transmission capacity by only replacing the existing conductors with more efficient high-temperature conductors, based on real investment, are evaluated at 2.000.000,00 €. Transmission switching, in case scenarios 3 and 5, can be used in the existing network, so no additional costs are necessary.

Investment in phase shifting autotransformer (Case study 1) is high, but in this case it provides a long-term solution for managing power flow in the area, so the investment is justified. N-1 criteria violation issues can be efficiently solved by integration of battery energy storage system and possible usage of transmission switching. High investment costs for integration of battery energy storage can be justified by using battery energy storage in providing additional ancillary services in regulation of power system, such as primary and secondary frequency regulation, peak shaving, etc., in times when N-1 criterion is not endangered.

5. CONCLUSION

Managing power flow in the power system network is a complex assignment. It is necessary to maintain the safety of the network in means of ensuring the possibility of transmitting all generated power to consumers without overloading the transmission equipment, while maintaining the most efficient and economical generation schedule. Integration of non-dispatchable renewable generation makes this assignment even more challenging.

In this work, alternate solutions to increase the capacity of transmission lines are presented and elaborated through simulations of part of a real power system. In a specific area of the Croatian power system, where 110 kV network is highly loaded, especially after integration of wind power plants, integration of phase shifting autotransformer with possibility of redirecting power flow to more stable and less loaded 220 kV network is presented as the long-term solution. However, N-1 criterion can be violated in case of an outage of this autotransformer, so integration of battery energy storage in the area is presented as a good solution to preserve N-1 criterion, especially in combination with transmission switching, which yields the best results. High costs of battery energy storage can be justified by utilizing it in providing ancillary services to the power system.

6. REFERENCES

1. <http://w3.siemens.com/smartgrid/global/en/products-systems-solutions/software-solutions/planning-data-management-software/planning-simulation/Pages/PSS-E.aspx>
2. Hedman, K. W., Oren, S. S. and O'Neill, R. P., A review of transmission switching and network topology optimization, in 2011 IEEE Power and Energy Society General Meeting, 2011, pp. 1–7.
3. Khorram, S. A. T., Fard, A. A. T., Fotuhi-Firuzabad, M. and Safdarian, A., Optimal transmission switching as a remedial action to enhance composite system reliability, in *2015 Smart Grid Conference (SGC), 2015*, pp. 152–157.
4. Khanabadi, M., Ghasemi, H. and Doostizadeh, M., Optimal Transmission Switching Considering Voltage Security and N-1 Contingency Analysis, *IEEE Trans. Power Syst.*, vol. 28, no. 1, pp. 542–550, Feb. 2013.
5. H. Pandzic, Y. Wang, T. Qiu, Y. Dvorkin, D. Kirschen, "Near-optimal method for siting and sizing of distributed storage in a transmission network", *IEEE Trans. Power Syst.*, vol. 30, no. 5, pp. 2288-2300, Sep. 2014.
6. Obio, E. B. and Mutale, J., A comparative analysis of energy storage and N-1 network security in transmission expansion planning, *Power Engineering Conference (UPEC), 2015 50th International Universities*, INSPEC Accession Number: 15649955, DOI: 10.1109/UPEC.2015.7339947
7. Wen, Y., Guo, C., Kirschen, D. S. and Dong, S., Enhanced Security-Constrained OPF With Distributed Battery Energy Storage, *IEEE Trans. Power Syst.*, vol. 30, no. 1, pp. 98–108, Jan. 2015.
8. Wen, Y., Guo, C., Pandžić, H. and Kirschen, D. S., Enhanced Security-Constrained Unit Commitment With Emerging Utility-Scale Energy Storage, *IEEE Trans. Power Syst.*, early access.
9. <http://www.renewableenergyworld.com>
10. Yli-Hannuksela, J., The Transmission Line Cost Calculation, University of Applied Science, 2011.