

NPP Krško Station Blackout Analysis after Safety Upgrade Using MELCOR Code

Siniša Šadek, Davor Grgić, Vesna Benčik

University of Zagreb Faculty of Electrical Engineering and Computing

Unska 3, 10000 Zagreb, Croatia

sinisa.sadek@fer.hr, davor.grgic@fer.hr, vesna.bencik@fer.hr

ABSTRACT

The analysis of a Station blackout (SBO) accident in the NPP Krško including thermal-hydraulic behaviour of the primary system and the containment, as well as the simulation of the core degradation process, release of molten materials and production of hydrogen and other incondensable gases will be presented in the paper. The calculation model includes the latest plant safety upgrade with addition of Passive Autocatalytic Recombiners (PAR) and the Passive Containment Filter Venting (PCFV) system. The code used is MELCOR, version 1.8.6. MELCOR is an integral severe accident code which means that it can simulate both the primary reactor system, including the core, and the containment. The code is being developed at Sandia National Laboratories for the U.S. Nuclear Regulatory Commission.

The analysis is conducted in two steps. First, the steady state calculation is performed in order to confirm the applicability of the plant model and to obtain correct initial conditions for the accident analysis. The second step is the calculation of the SBO accident with the leakage of the coolant through the damaged reactor coolant pump seals. Without any active safety systems, the reactor pressure vessel will fail after few hours. The mass and energy releases from the primary system cause the containment pressurization and rise of the temperature. The newly added safety systems, PAR and PCFV, prevent the damage of the containment building by keeping the thermal-hydraulic conditions below the design limits. The analysis results confirm the capability of the safety systems to effectively control the containment conditions.

Results of the analysis are given with respect to the results of the MAAP 4.0.7 analysis for the same accident scenario. The MAAP and MELCOR codes are the most popular severe accident codes and, therefore, it is reasonable to compare their results. In addition, sensitivity calculations performed by varying most influential parameters, such as the hot leg creep failure, blockage of a pipe connecting the cavity and the sump, inclusion of a radionuclide package in the MELCOR, etc. are done in order to demonstrate correct physical behaviour and the accuracy of the developed NPP Krško MELCOR model.

Keywords: station blackout, core degradation, MELCOR, PCFV, containment integrity

1 INTRODUCTION

Following the lessons learned from the accident at the nuclear power plant Fukushima in Japan and according to the Slovenian Nuclear Safety Administration (SNSA) Decree No. 3570-11/2011/7 on September 1, 2011 [1], Nuclear Power Plant Krško (NEK) decided to take the necessary steps for upgrade of safety measures to prevent severe accidents and to improve the means to successfully mitigate their consequences. Consequently, the first modifications that NEK

implemented during the Outage 2013 were the installation of Passive Autocatalytic Recombiners (PAR) and Passive Containment Filtered Vent (PCFV) systems.

The objective of the paper is to analyze the plant response following the station blackout (SBO) accident with the severe accident code MELCOR 1.8.6 in order to demonstrate its applicability to correctly simulate plant behaviour after implementation of the containment passive safety systems. Furthermore, results of the analysis will be given with respect to the results of the MAAP 4.0.7 analysis for the same accident scenario. The MAAP 4.0.7 calculation results were originally used for the designing of the PAR and PCFV systems and the SBO scenario analyzed herein is similar to those previous runs [2].

The SBO accident includes the loss of all AC power, main feedwater pumps, auxiliary feedwater pumps, safety injection (high and low pressure) pumps, containment sprays, reactor coolant pumps and containment fan coolers. No operator actions are modelled. The reactor coolant pump (RCP) seal injection flow provided by charging pump will be lost and the break at RCP will open. The break flow through the RCP seals of 21 gpm (0.0013 m³/s) is assumed in the calculation [2].

The MELCOR code [3], [4] is a fully integrated, engineering-level computer code whose primary purpose is to model the progression of accidents in light water reactor nuclear power plants. A broad spectrum of severe accident phenomena in both boiling and pressurized water reactors is treated in MELCOR in a unified framework. Current uses of MELCOR include estimation of fission product source terms and their sensitivities and uncertainties in a variety of applications. The MELCOR code is composed of an executive driver and a number of major modules, or packages, that together model the major systems of a reactor plant and their generally coupled interactions.

Initially, the MELCOR code was envisioned as being predominantly parametric with respect to modelling complicated physical processes (in the interest of quick code execution time and a general lack of understanding of reactor accident physics). However, over the years as phenomenological uncertainties have been reduced and user expectations and demands from MELCOR have increased, the models implemented into MELCOR have become increasingly best estimate in nature. Today, most MELCOR models are mechanistic, with capabilities approaching those of the most detailed codes of a few years ago. The use of models that are strictly parametric is limited, in general, to areas of high phenomenological uncertainty where there is no consensus concerning an acceptable mechanistic approach.

2 MELCOR MODEL OF THE NPP KRŠKO

2.1 Models of the RCS and the Secondary System

The primary and secondary systems, including regulation systems and control volumes that represent boundary conditions, consist of 104 thermal-hydraulic control volumes, 125 flow junctions and 48 heat structures. The nodalization scheme of primary and secondary systems is shown in Figure 1.

Hot legs in each loop are modelled with two control volumes (CV), intermediate legs with four and cold legs with one volume. Reactor coolant pumps are defined by pressure heads and its respective volumes are added to adjacent control volumes. The pressurizer is modelled with two CVs (103 and 105), while the volume CV 104 represents the pressurizer relief tank where pressurizer power operated relief (PORV) and safety valves (SV) discharge steam. CV 109 and CV 209 represent accumulators. The steam generator (SG) inlet part is modelled with one volume, the outlet part also with one CV, and U-tubes with six control volumes. On the secondary side, SG downcomer is modelled with one CV, riser section with four and the SG separator and the dome with one CV. Auxiliary and main feedwater (MFW) flow are directed into the SG downcomer taking suction from the control volumes CV 503 and CV 513 for the MFW, and CV 504 and CV 514 for the AFW flow. SG safety and relief valves (FL375-FL380 for SG 1 and FL475-FL480 for

SG 2) discharge steam into CV 921 for the first and CV 922 for the second steam generator. Steam lines from the steam generators 1 and 2 are represented by control volumes 811 and 812. The steam header and the steam line to the turbine are represented with the control volumes 813 and 814, respectively. CV814 is connected to CV 901 (pressure boundary condition that simulates the turbine) by the valve that closes after the turbine trip. In the steady state calculation the valve opening is modulated to obtain the referent reactor coolant system (RCS) average temperature.

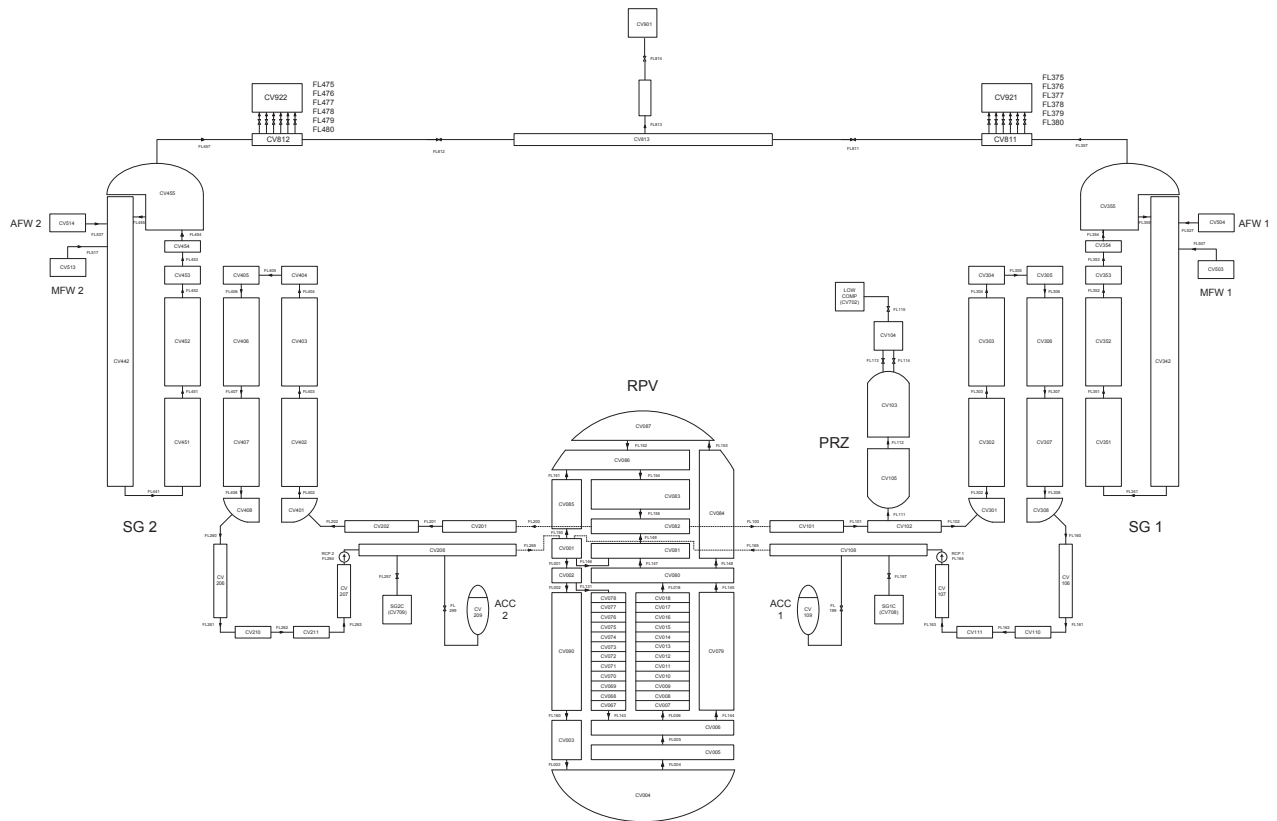

Figure 1: NEK nodalization for MELCOR 1.8.6 code calculation

2.2 Reactor Pressure Vessel and Core Models

The reactor pressure vessel (RPV) is modelled with 40 control volumes. The lower plenum is represented with 3 CVs, the downcomer with 5 CVs, the upper plenum with 4 CVs and the upper head with 2 CVs. One CV was used to represent RCCA guide tubes (CV 084). The flow inside the reactor core was represented with 12 control volumes (CV 007-018), as well as the baffle-barrel flow (CV 067-078). The guide tubes bypass inside the core was represented with one control volume (CV 079).

The height of one control volume inside the core is 0.3048 m, because the total core height is 3.6576 m.

Axial representation of the reactor core and the lower plenum used in the MELCOR COR package is shown in Figure 2. Seven radial rings are used to represent the RPV, 5 rings for the core, one ring for the region between the baffle and the barrel, and one additional ring in the lower plenum as requested by the code. The lower head is represented with more radial rings (10) for better prediction of the RPV wall temperature which is used to calculate the RPV rupture.

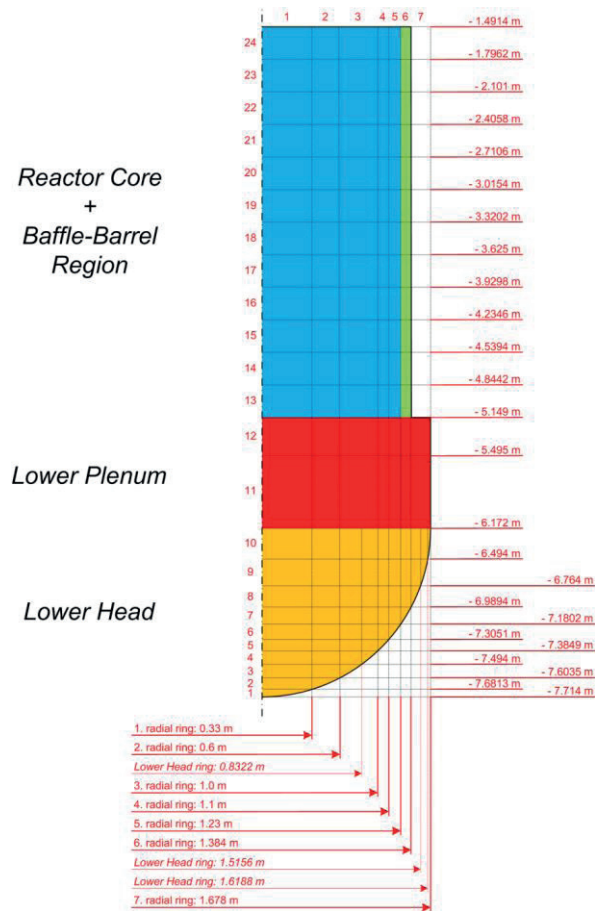

Figure 2: Axial representation of the reactor core and the lower plenum used in the COR package

2.3 Containment Model

The NEK containment model is based on the NPP Krško containment nodalization notebook [5] which contains detailed calculations of containment free volume and heat structures' dimensions, and data of the containment geometry. Containment nodalization is shown in Figure 3.

The containment building is represented with 12 control volumes:

1. CV 701 (containment dome) – cylindrical/spherical air space above the reactor pool, steam generators and pressurizer compartments,
2. CV702 (lower compartment) – lower compartment below the containment dome placed between SG1, SG2 and PRZ compartments excluding the reactor pool and the reactor pressure vessel area,
3. CV 703 (pressurizer compartment) – air space in the compartment that contains pressurizer and primary system safety and relief valves,
4. CV 704 (reactor cavity) – air space below the reactor vessel including the instrumentation tunnel,
5. CV 705 (annulus) – air space between the steel liner and the containment building,
6. CV 708 (steam generator 1 compartment) – air space in the SG1 compartment that contains components SG1 and RCP1,
7. CV 709 (steam generator 2 compartment) – air space in the SG2 compartment that contains components SG2 and RCP2,
8. CV 710 (reactor pool) – air space above the reactor vessel filled with water during the shutdown, otherwise empty,
9. CV 711 (around reactor vessel) – air space between the reactor vessel and the primary shield walls,

- CV 712, 713, 714 (containment sump) – the lowest control volumes below the SG1 compartment and the lower compartment that contain recirculation and drainage sumps.

There are three additional volumes:

- CV 706 – refuelling water storage tank,
- CV 707 – connection between the upper compartment and the environment, added to control opening/closing of the PCFV relief valve,
- CV 900 (environment) – a large volume (10^8 m^3) at constant temperature (307 K) and pressure (10^5 Pa).

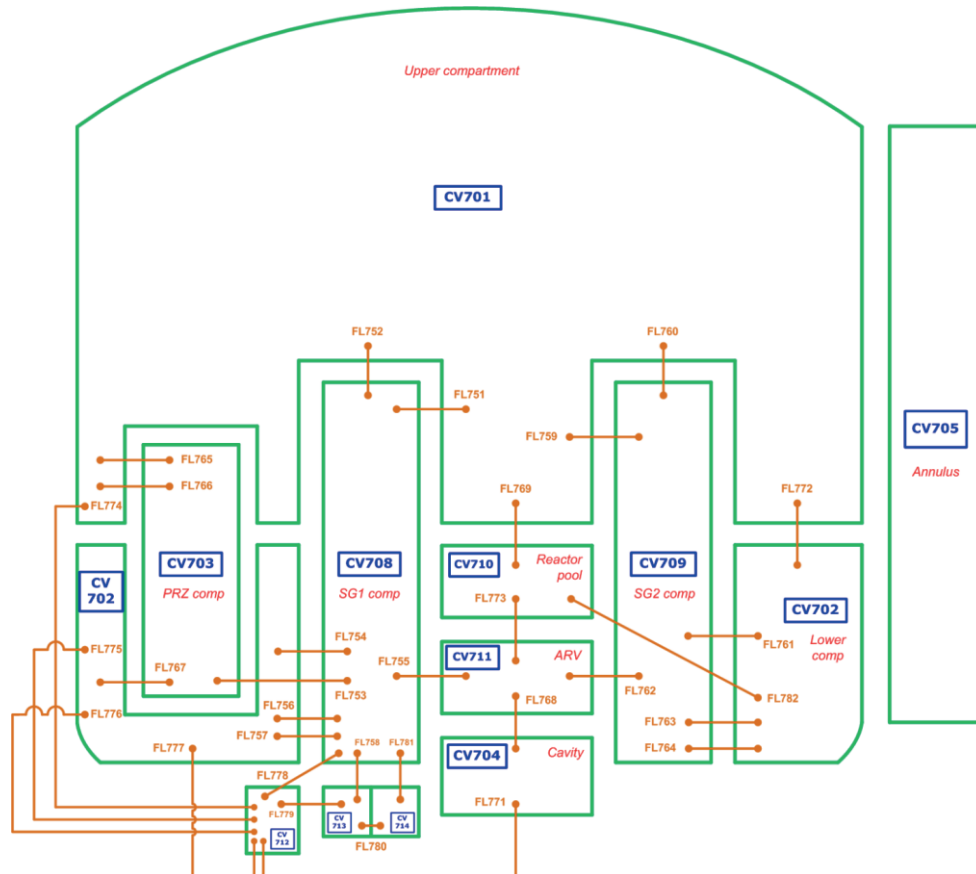

Figure 3: Containment NEK nodalization

Containment control volumes are connected by 30 junctions and heat sinks representing outside containment wall, internal walls, floors, polar crane, fan coolers, platforms, other miscellaneous stainless and carbon steel structures are modelled with 20 heat structures. Additional information about the containment model can be found in [6].

2.4 Transient Description

The analyzed transient is a standard SBO accident where no active components such as pumps and fans are available. The accident also involves release of coolant through damaged RCP seals with a leakage rate of 21 gpm ($0.0013 \text{ m}^3/\text{s}$) per one reactor coolant pump. In addition, the letdown line is assumed to be isolated which consequently leads to the opening of the letdown relief valve to the pressurizer relief tank increasing the coolant loss from the RCS. Taking this into account, break flow areas are set to $1.8 \cdot 10^{-5} \text{ m}^2$ for the loop 1 and to $9.5 \cdot 10^{-5} \text{ m}^2$ for the loop 2 (which letdown line is attached to).

Unmitigated SBO sequence of events will include core degradation and melting, RPV rupture and release of corium in the containment cavity, interaction between the corium and concrete (MCCI), release of incondensable gases and containment pressurization. Passive autocatalytic recombiners are used to control hydrogen concentration and the PCFV system restricts containment pressure below the rupture limit.

3 ANALYSIS AND RESULTS

3.1 Thermal-Hydraulic Conditions in the RCS and the Core Meltdown

The results of the MELCOR calculation were compared with results of the MAAP code [7] calculation. On most of the diagrams, they were put together to highlight similarities and differences between the codes. The MAAP 4.0.7 code version and the NEK model of the plant [8] that includes PARs and the PCFV system based on the latest calculation performed by NEK [2] was used in the MAAP calculation. The intention of both calculations is to support licensing review process and demonstrate adequacy of introduced modifications as part of the NEK safety upgrade project.

The accident started with the closure of the turbine valve, trip of the RCPs and the reactor trip. The primary pressure (Figure 4) rose sharply at the beginning of the transient due to termination of the reactor coolant flow, but immediately afterwards, loss of coolant through the breaks at RCP seals lead to the primary pressure decrease. In the meantime, SG pressure oscillated around 8 MPa (Figure 5) due to periodical openings of SG safety valves. After 2000 s the primary pressure increased once again to 16 MPa and remained at that value until the hot leg pipe ruptured at 9700 s. The rupture was due to the creep thermal and mechanical stress and deformation caused by the hot vapour at high pressure coming from the reactor core. The pressure was maintained by the operation of pressurizer safety valves. The break flow rate was not large due to relatively small break area of the RCP pump seals. The limited leakage rate from the breaks, in combination with the loss of forced circulation in the RCS and the unavailability of the secondary heat sink, resulted in the primary system overheating (Figure 6) and the increase of the pressurizer pressure. Since the pressure, prior to the hot leg failure, never dropped to a value of 5 MPa, no accumulators' injection into the cold legs occurred in that period.

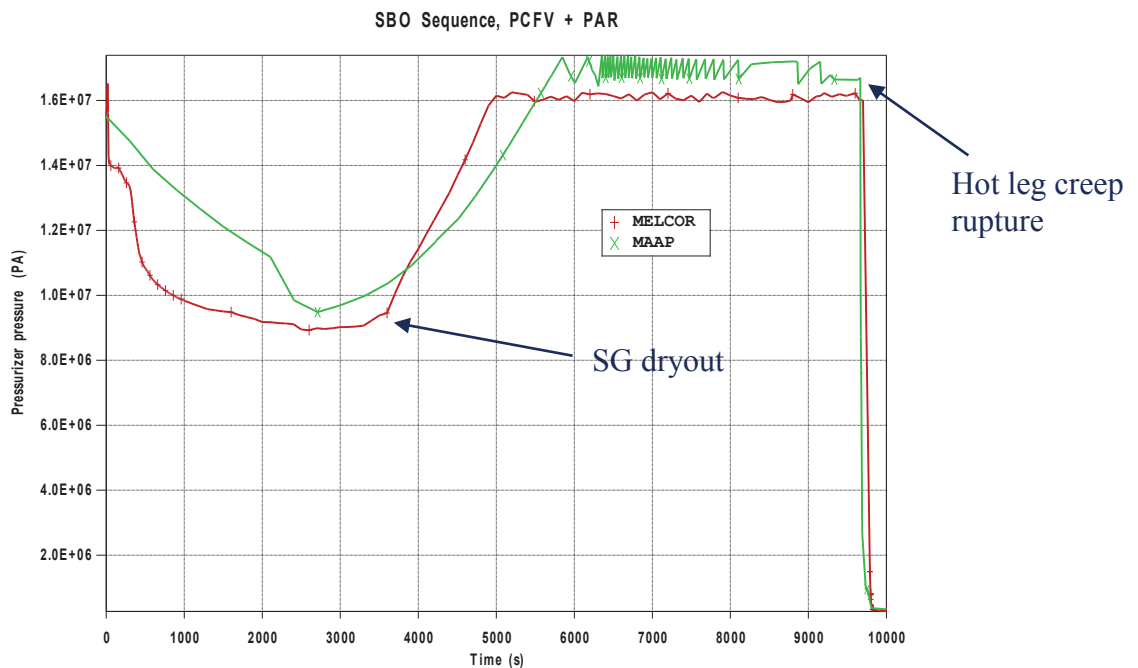

Figure 4: Pressurizer pressure

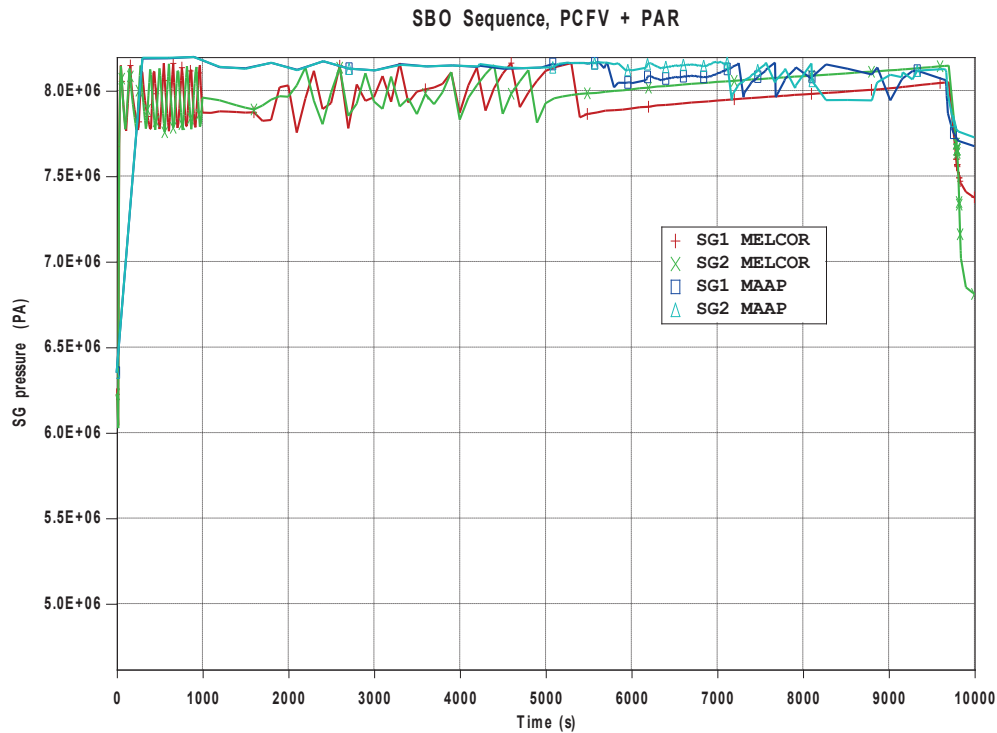

Figure 5: Steam generator pressure

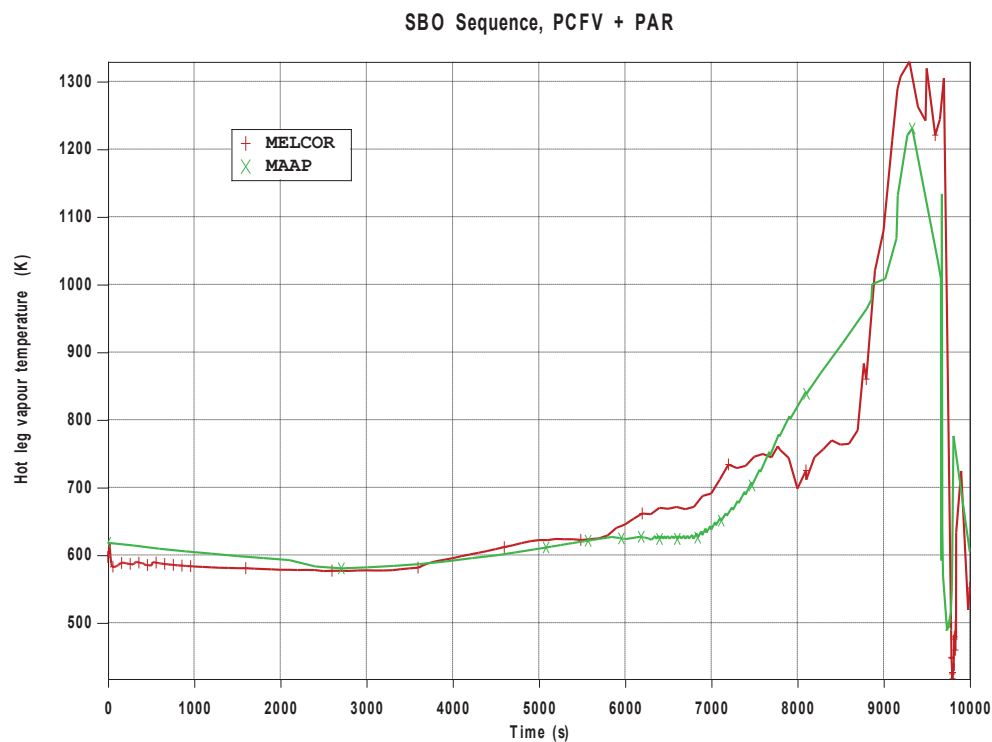

Figure 6: Hot leg vapour temperatures

As more and more water was discharged from the RCS to the containment, the core started to uncover and to heat up. The upper core levels uncovered at 6000 s, and the lower levels at 7500 s. The core heatup was additionally supported with oxidation of fuel rod cladding and other metallic materials. The mass of hydrogen produced during oxidation in the core was about 250 kg.

Since there was no water injection to stop the temperature increase, the core began to melt, first the inner fuel elements and later the outer ones. The process lasted about one hour. The melt front eventually propagated to the core boundary where the melt breached through the core baffle plates and relocated to the lower plenum. Relocation of the molten material to the RPV lower head caused heatup and failure of the reactor vessel wall at about 20000 s. The break was due to the creep failure as the consequence of the material fatigue when exposed to high thermal and mechanical stress. Damage of the reactor pressure vessel led to release of the corium into the containment cavity and start of the molten corium concrete interaction (MCCI). The mass of corium released from the vessel was around 80 tons.

3.2 Containment Behaviour and the Molten Corium Concrete Interaction

Heat transfer from the hot corium (~2000 K) to water in the cavity caused the water to evaporate. The released steam was a major contributor to containment pressurization (Figure 7). Cavity was initially empty, but the coolant released from the RCS drained into the containment sump and from there it entered the cavity. The cavity has dried out rather quickly (Figure 8). The time of the cavity dryout coincided with the point of termination of the fast pressure increase rate.

Connection between the sump and the cavity by the 4 inch pipe enabled water to enter and to flood the cavity from the start of the accident. About 60000 kg of water was present in the cavity before the vessel ruptured. The pipe was closed after the failure of the reactor pressure vessel and the release of the corium. The volume of corium is large and it is reasonable to assume that the narrow pipe will be blocked once when filled with the melt. The blockage means that there will be no more water flow from the sump to the cavity causing the fast water depletion in the cavity.

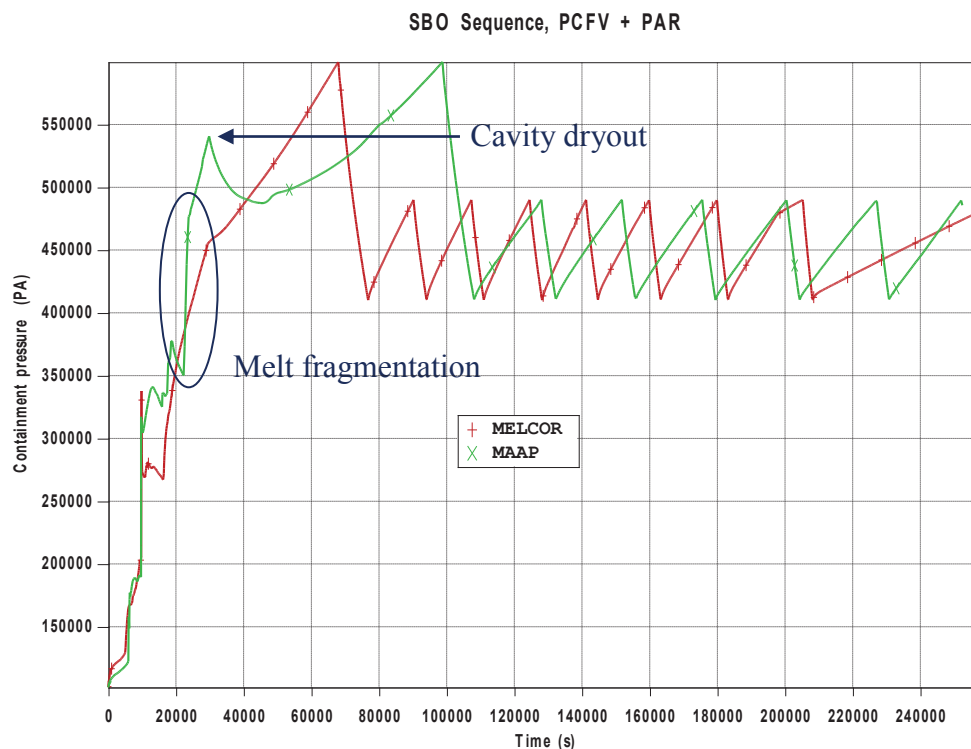

Figure 7: Pressure in the containment upper plenum

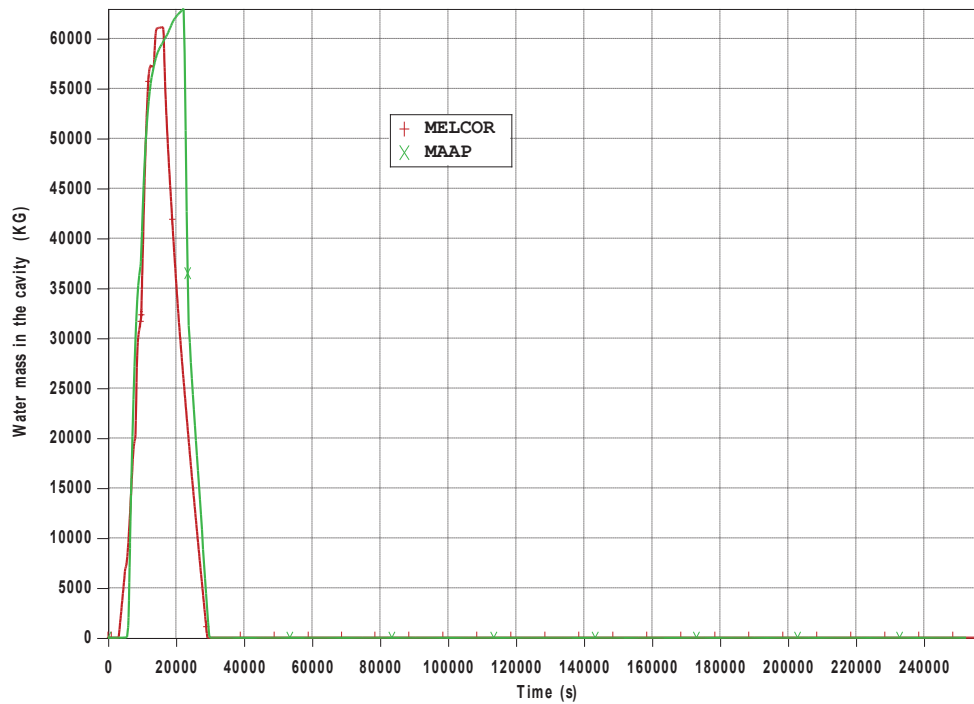

Figure 8: Mass of water in the reactor cavity

MELCOR calculated the first pressure peak to occur 30000 s earlier than MAAP. MAAP assumes that the melt is fragmented and quenched when it is submerged in water. MELCOR does not take the possibility of quenching into account which means that the melt is all the time at the high temperature. Therefore, after the water in the cavity evaporates, containment pressure and temperature (Figure 9) start to rise immediately in the MELCOR calculation, while in MAAP there is a time delay because the relocated material first has to be heated up by the decay heat and only after that the heat can be transferred in the containment atmosphere.

The pressure profile follows the PCFV system logic of controlling containment conditions. There are two components in the filtered venting line which behaviour depends on the pressure, the rupture disc and the relief valve. The rupture disc ruptured at 68000 s (MELCOR case) when the containment pressure reached 6 bar (the first pressure peak in Figure 7). Later, the pressure was cycling between 4.1 bar and 4.9 bar by the operation of the PCFV relief valve that had a hysteresis characteristic. The relief valve was closed when the pressure dropped below 4.1 bar and opened after it increased above 4.9 bar.

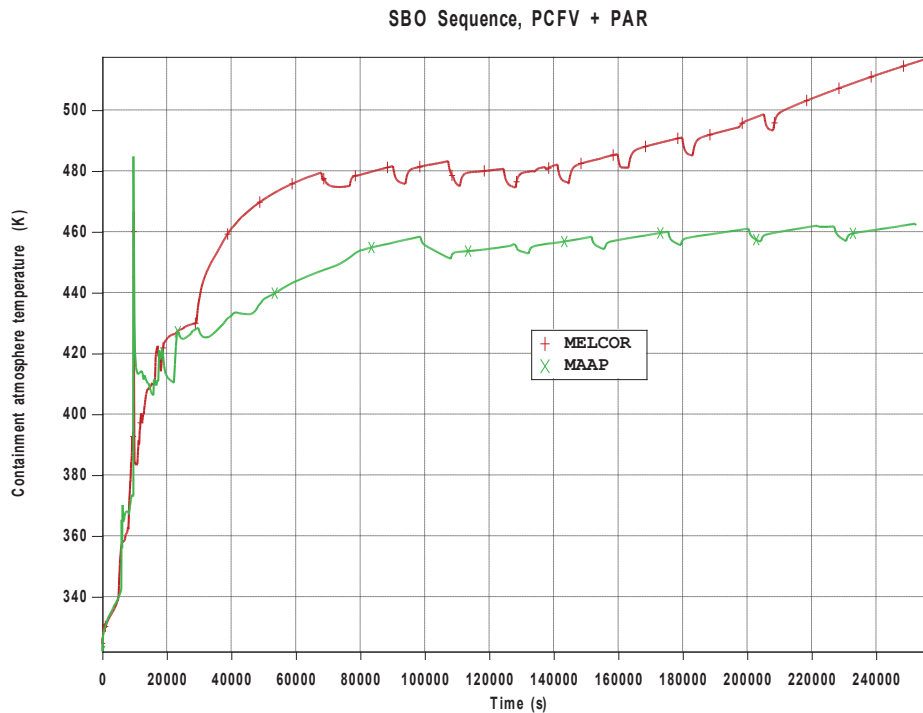

Figure 9: Temperature in the containment upper plenum

The reaction between the molten corium and the concrete (MCCI) erodes containment basemat (Figure 10) and results with production of incondensable gases: hydrogen, carbon monoxide and carbon dioxide. Hydrogen and CO are released during oxidation of iron contained in concrete rebar with steam, produced by evaporation of water bounded in the concrete, and CO₂, respectively. Carbon dioxide is released during decomposition of calcium carbonate (CaCO₃) into calcium oxide (CaO) and CO₂. Figure 11 shows total gas releases due to the molten corium concrete interaction as calculated by MELCOR. Those gases also contribute to overall containment pressurization.

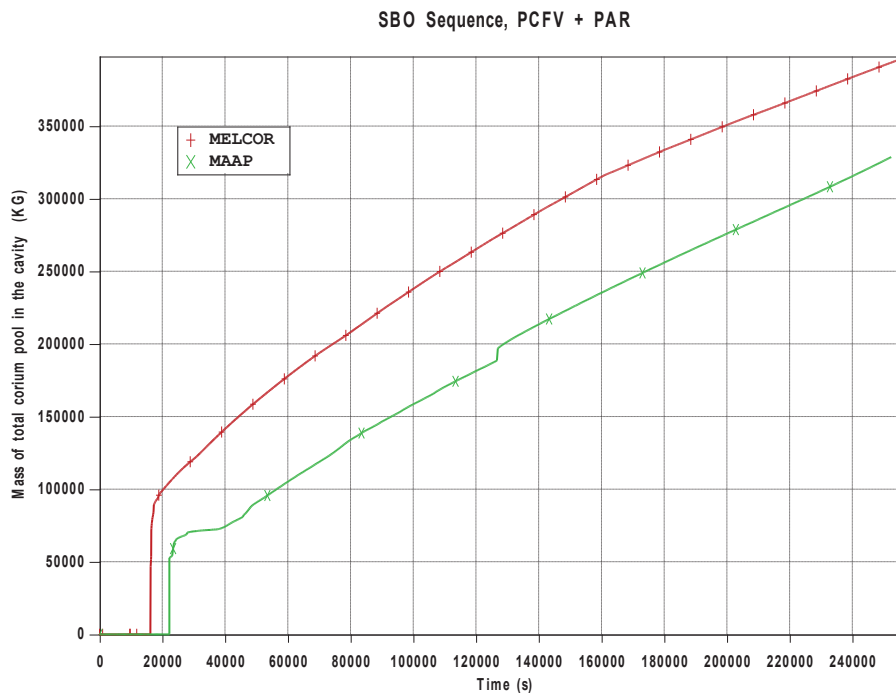

Figure 10: Mass of the total corium pool in the reactor cavity

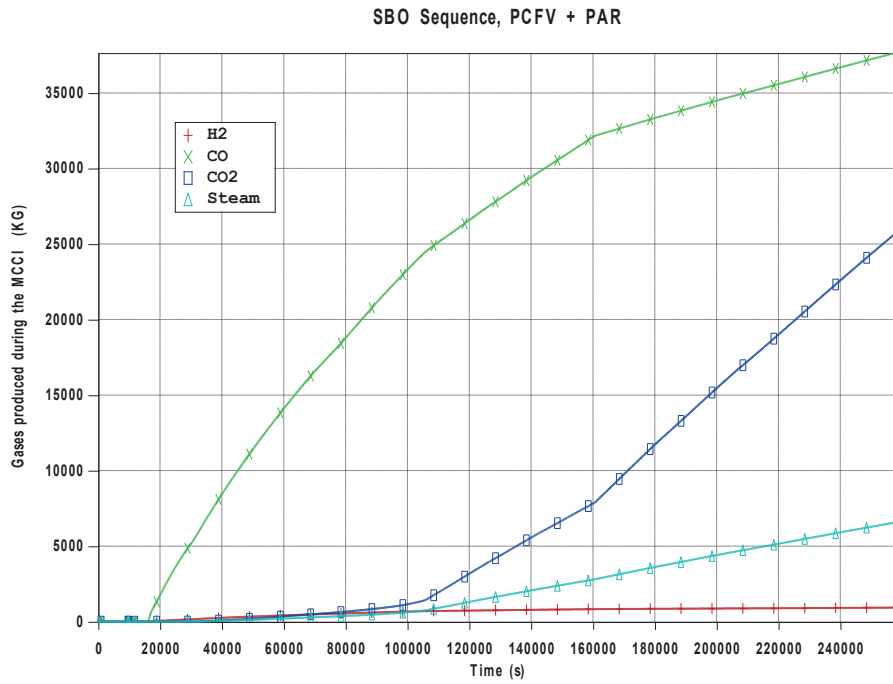

Figure 11: Gases released during the MCCI, MELCOR calculation

There are 22 PAR units installed in the containment. Passive autocatalytic recombiners are used to control hydrogen concentration in the containment by forcing the reaction between hydrogen and oxygen. PARs removed 850 kg of hydrogen which is about 80% of hydrogen produced by the oxidation in the core and the MCCI. Comparison between the hydrogen production and recombination rates is shown in Figure 12. PAR operation started when hydrogen mole fraction reached value of 0.02 and stopped after oxygen mole fraction dropped to 0.005.

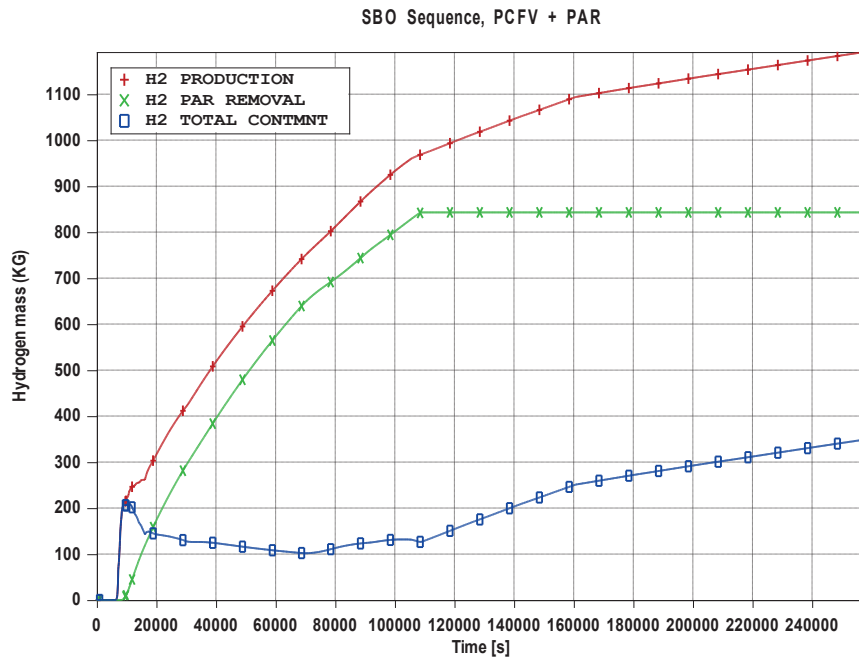

Figure 12: Hydrogen production, hydrogen mass removed by PARs and total hydrogen mass in the containment, MELCOR calculation

3.3 Sensitivity Calculations

The reference analysis was performed with the blocked pipe that connects the sump and the cavity. It was assumed that after the corium is released from the reactor vessel, it would block the pipe and stop the flow of water and steam. The sensitivity calculation with the pipe opened throughout the transient was performed to evaluate the influence of constant water flow between the sump and the cavity.

Containment pressure behaviour is much different if the flow in the pipe is not blocked (Figure 13). The reason is that water in the cavity is now depleted much later. The water evaporates at the same rate but it is being constantly added from the containment sump. Steam that condensates in the containment finishes eventually in the sump because all the drainages paths lead to the sump. Thus, the sump never dries out completely and as long as the upper elevation of water in the sump is higher than the bottom of the cavity, water will enter into the cavity. That water dries out and the steam pressurizes the containment. The pressure of 6 bars, when the PCFV rupture disk fails, is reached before the cavity dryout and so the whole sequence of opening and closing the PCFV relief valve takes place much earlier than in the previous sequence.

The MELCOR radionuclide (RN) package calculates fission product release and transport inside the circuits and the containment. Including the package, decay heat of released products will additionally heat up and pressurize the containment as can be seen in Figure 13.

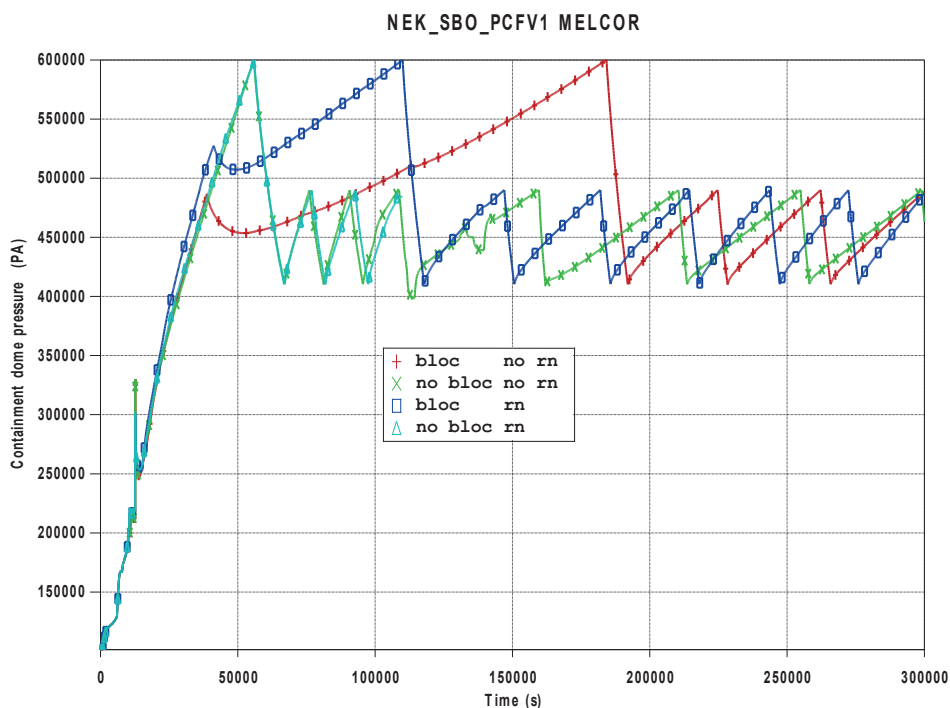

Figure 13: Pressure in the containment upper plenum, MELCOR calculation

In the SBO analysis the occurrence of the hot leg creep failure prior to the RPV rupture was assumed. Additional calculations were performed to check the influence of such assumption on the containment behaviour. After the introduction of the hot leg creep rupture, containment pressure rose faster, Figure 14. When there was no hot leg creep, the RCS was at a high pressure until the RPV failure. The accumulators then discharged water directly into the containment cavity through the break in the reactor vessel. More water in the cavity in the case with no hot leg creep failure provided more efficient cooling of the melt and less heat release in the containment. Thus, containment pressure and temperature increased slower when no hot leg creep failure was modelled.

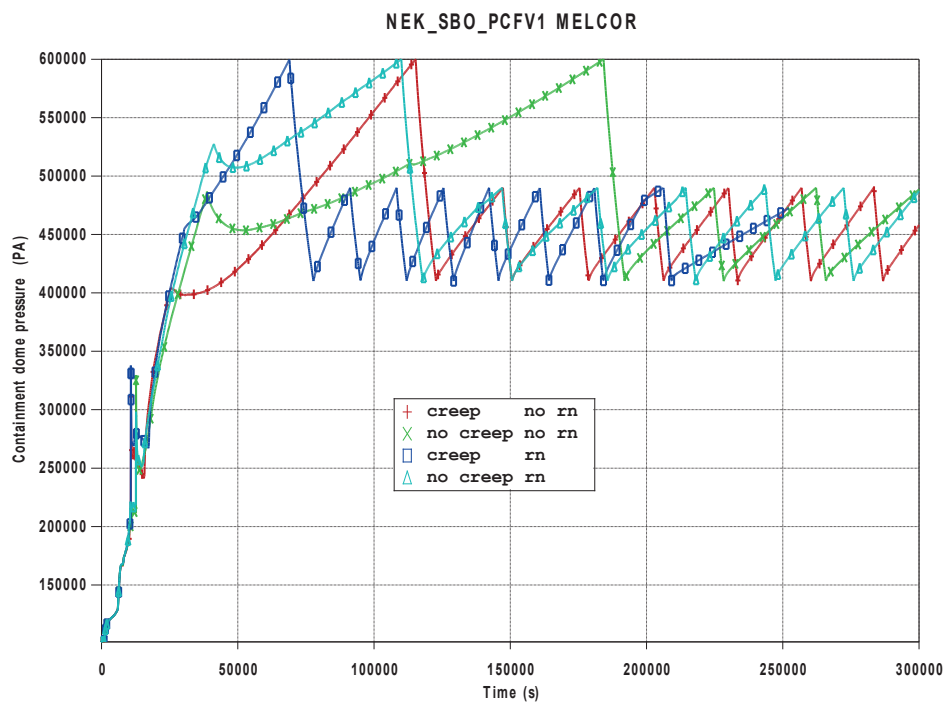

Figure 14: Pressure in the containment upper plenum, MELCOR calculation

4 CONCLUSION

A postulated station blackout accident at the NPP Krško with PAR and PCFV systems was analyzed with the MELCOR 1.8.6 code and its results were compared with the MAAP 4.0.7 calculation of the same transient scenario. The sequence of events included total core meltdown due to unavailability of safety injection, release of corium in the containment and containment pressurization by steam and incondensable gases and decay heat release from the melt. The PCFV system provided controlled release of containment inventory and kept the pressure at the system design limits. Passive autocatalytic recombiners reduced the hydrogen concentration by maintaining the chemical reaction between hydrogen and oxygen.

The MELCOR model of the primary and secondary systems, including regulation systems and boundary conditions, consisted of 104 thermal-hydraulic control volumes, 125 flow junctions and 48 heat structures. The reactor pressure vessel (RPV) was modelled with 40 control volumes. The reactor core and the lower plenum used were represented with 24 axial seven radial rings, 5 rings for the core, one ring for the region between the baffle and the barrel, and one additional ring in the lower plenum as requested by the code. The containment was divided in 12 thermal hydraulic control volumes. Three volumes instead of one were used to represent sump in order to realistically predict water drainage from other containment compartments and water supply to the cavity.

Calculation results support PCFV and PAR systems performance in controlling containment conditions during severe accidents. MELCOR and MAAP code predictions were similar except when parametric approach used in MAAP considerably influenced transient propagation. That was the case in predicting the first containment pressure peak which occurred later in the MAAP calculation due to the selection of melt fragmentation option in the cavity water. Fragmentation of the corium jet led to the fast melt cooldown and slower pressure increase once when the water evaporated. Models in MELCOR are mainly mechanistic and the plant behaviour is calculated based on the empirical correlations adopted in the code. In the analysed SBO scenario MELCOR did not calculate melt fragmentation and thus the pressure and temperature rise went faster. Nevertheless, overall system behaviour was similar to results obtained in the PCFV design calculation.

Sensitivity calculations that simulated the influence of a blockage of a 4 inch pipe connecting the sump and the cavity and the hot leg creep rupture on the containment thermal hydraulic conditions demonstrate the correct physical behaviour and the accuracy of the developed NPP Krško MELCOR model to predict plant behaviour with respect to varying initial and boundary conditions.

REFERENCES

- [1] SNSA Decree No.: 3570-11/2011/7, “Odločba o izvedbi modernizacije varnostnih rešitev za preprečevanje težkih nesreč in blažitev njihovih posledic (SNSA Decree on Implementation of modernization of safety solutions for prevention of severe accidents and mitigation of their consequences)”, September 2011.
- [2] Špalj, S., NPP Krško MAAP Analysis of Station Blackout (SBO) Accident Following Passive Containment Filtered Vent (PCFV) System and Passive Autocatalytic Recombiners (PAR) Installation, NEK ESD-TR-08/14, NEK, 2014.
- [3] Gauntt, R. O., Cash J. E., Cole R. K., Erickson C. M., Humphries L.L., Rodriguez S. B., Young M. F., MELCOR Computer Code Manulas, Vol. 1: Primer and Users’ Guide, Version 1.8.6, Sandia National Laboratories, Albuquerque, September 2005.
- [4] Gauntt, R. O., Cash J. E., Cole R. K., Erickson C. M., Humphries L.L., Rodriguez S. B., Young M. F., MELCOR Computer Code Manulas, Vol. 2: Reference Manuals, Version 1.8.6, Sandia National Laboratories, Albuquerque, September 2005.
- [5] Fancev, T., Grgić, D., NEK Containment Nodalization Notebook, NEK ESD-TR18/00, FER-ZVNE/SA/DA-TR49/00-0, Revision 0, 2000.
- [6] Šadek, S., Grgić, D., Benčik, V., Analysis of the NPP Krško Station Blackout Accident with PAR and PCFV Using MELCOR 1.8.6 Code, FER-ZVNE/SA/DA-TR01/15-1, Revision 1, 2015.
- [7] Hammersley, R. J., Landgren, V. D., MAAP 4.0.7 User’s Manual, Fauske and Associates, LLC, June 2007.
- [8] Glaser, B., Bilić Zabric, T., NEK MAAP4 Parameter File Notebook, NEK ESD-TR-02/00, Revision 0, NEK, 2000.